

# TELEVISION ENGINEERING

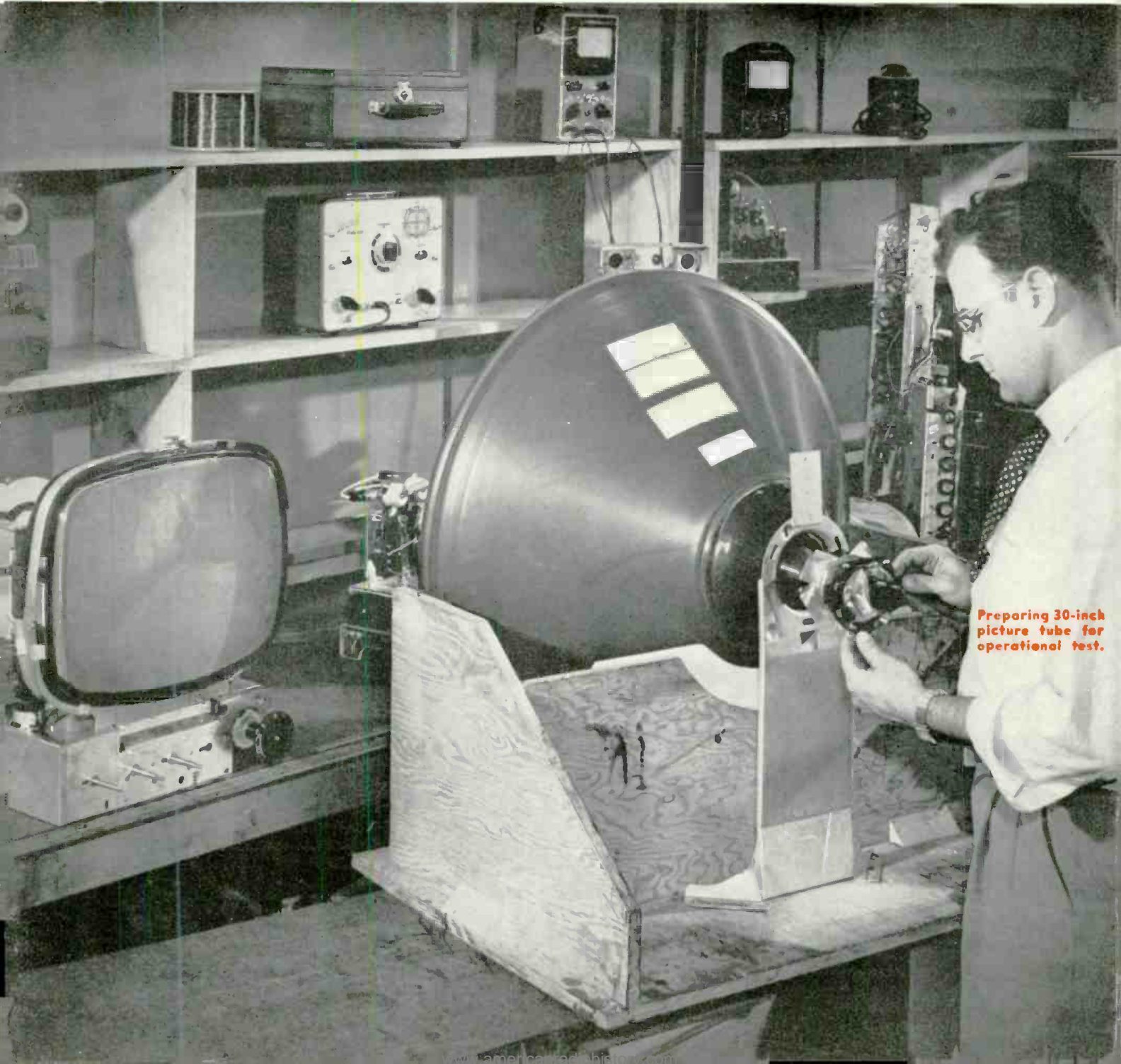

MAY, 1951

*The News-Engineering Journal of The TV Industry*



Preparing 30-inch picture tube for operational test.

# A STANDARD VIDEO LEVEL MEASURING SCOPE

*and Precision...*

## DUMONT waveform monitor



Du Mont proudly announces the availability of the **FIRST** precision video waveform monitoring and measuring equipment to meet the stringent requirements of quality television broadcasting. The Du Mont TA-169-A Waveform Monitor and power supply (not shown) combines amplitude linearity over large deflection with wide bandwidth and no overshoot, yielding a truer measure of a video signal than is

achievable on ANY standard TV equipment currently in use. A filter may be switched in to provide the standard amplitude-frequency response recommended by I. R. E. and R. T. M. A. for level setting measurements. A precise meter and calibrator are built in. Expanded sweeps show detail in equalizing pulses and front and back porches.

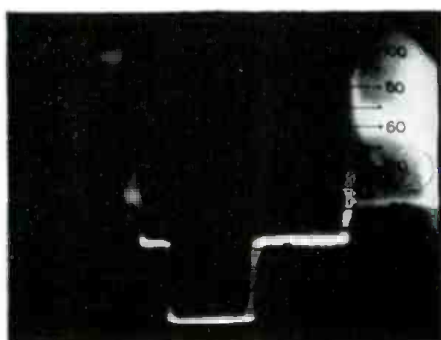

Expanded line sweep rate to inspect horizontal sync signal in detail.

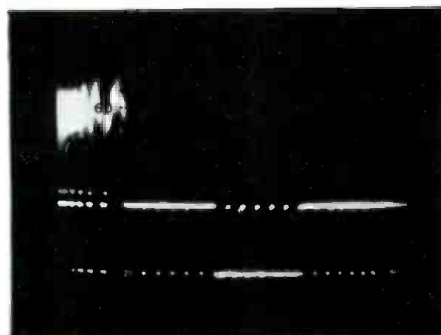

Expanded frame sweep rate to inspect vertical sync period — serrated and equalizing pulses in a single field — in detail.

### FEATURES:

- ✓ 7.5 mc bandwidth video amplifier with no detectable overshoot for rise time of 0.03 micro-seconds instantly switchable to standard I. R. E. 4 mc roll-off for level measuring.
- ✓ Peak-to-peak input signal of 0.2 to 3.0 volts produces full scale deflection (2.5") on CRT screen with amplitude linearity of better than 2%.
- ✓ Voltage calibration with accuracy of 2% is provided. High impedance input available on front panel, 75 ohm input on rear of chassis.
- ✓ Type 5268-A Power Supply supplies all high and low voltages.
- ✓ Filament transformer located in power supply to eliminate hum distortion.

*First with the Finest in Television*

**TELEVISION TRANSMITTER DIVISION**

ALLEN B. DU MONT LABORATORIES, INC.

1000 Main Avenue, Clifton, N. J.

# TELEVISION ENGINEERING

Including Radio Engineering, Communications and Broadcast Engineering. Registered U. S. Patent Office.

Research . . . Design . . . Production . . . Instrumentation . . . Operation

VOLUME 2

MAY, 1951

NUMBER 5

TVE-grams . . . . .	4
Defense Production News . . . Tube Fabrication Developments . . . Subminiature Design Trends . . . Filter Paper for Miniature Capacitors . . . Glass Soldering . . . Random Noise in Theatre TV . . . The Gray Scale in Video Systems.	
Design Features of 30-Inch TV Receivers . . . . .	Ricardo Muniz 10
Analysis of Circuitry and Layout Modifications Required for 526-Square-Inch Picture-Tube Chassis.	
Horizontal Deflection System Requirements . . . . .	John Narrace 12
Component and Circuit Factors Which Must Be Considered During Development, Design and Application.	
New Trends in Component Design . . . . .	Ralph G. Peters 14
Highlights of Capacitors and Resistors Now Being Produced for Video and Related Systems.	
Engineering a Super-Gain TV Antenna . . . . .	M. E. Hiehle 16
Design Considerations of Antennas for the Veryhigh and Ultra- high Bands.	
Cathode-Coupled Clipper Response Speed . . . . .	Philip F. Ordnung and Herbert L. Krauss 21
Part II of Probe Study, Covering Basic Circuits Employed and Typical Response Curves Obtained.	

## MONTHLY FEATURES

Viewpoints . . . . .	Lewis Winner 3
TVE-grams . . . . .	4
Personals . . . . .	9
Industry Literature . . . . .	23
Production Aids . . . . .	24
TV Parts and Accessory Review . . . . .	24
Instrument News . . . . .	25
Veteran Wireless Operators' Association News . . . . .	26
Advertising Index . . . . .	30
Briefly Speaking . . . . .	31

## Cover Illustration

Installing a 30° deflection yoke on neck of 30-inch picture tube, prior to testing its operation.  
(Courtesy DuMont; photo by Norman Germond.)

Editor: LEWIS WINNER



Published monthly by Bryan Davis Publishing Co., Inc., 52 Vanderbilt Avenue,  
New York 17, N. Y. Telephone: MUrray Hill 4-0170.

Bryan S. Davis, President. Paul S. Weil, Vice-Pres.-Gen. Mgr. Lewis Winner, Editorial Director.  
F. Walen, Secretary. A. Goebel, Circulation Manager.

Mid-West Representative: Stuart J. Osten, 333 N. Michigan Ave., Chicago 1, Illinois. Telephone: Dearborn 2-3507  
Eastern Representative: I. I. Brookman, 52 Vanderbilt Avenue, New York 17, N. Y.  
East-Central Representative: James C. Munn, 2253 Delaware Drive, Cleveland 6, Ohio. Telephone: ERievew 1-1726.  
Pacific Coast Representative: Brand & Brand, 1052 West 6th Street, Los Angeles 14, Cal. Telephone: Michigan 1732.  
Suite 1204, Russ Building, San Francisco 4, Cal. Telephone: SUtter 1-2251.

Reentered as second-class matter February 7, 1950 at the Post Office at New York, N. Y., under the act of March 3,  
1879. Subscription Price: \$3.00 per year in the United States of America and Canada; 50c per copy. \$4.00 per  
year in foreign countries; 60c per copy.

Te Aro Book Depot: Wellington, New Zealand. McGill's Agency: Melbourne, Australia.

TELEVISION ENGINEERING is indexed in the Engineering Index.  
Entire Contents Copyright 1951. Bryan Davis Publishing Co., Inc.



it's the "Steps  
between"

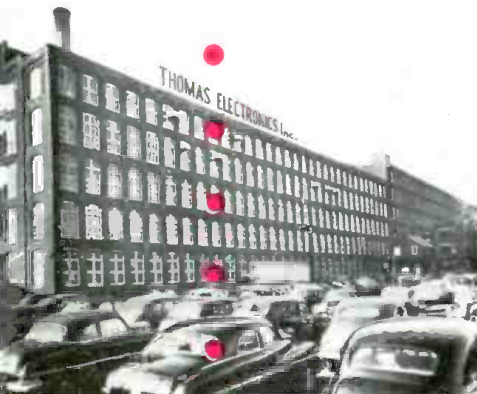

that make

**Thomas**  
**Photo-tron**  
PICTURE TUBES

**Superior!**

EVERY STEP in the making of a Thomas picture tube is followed through with the foresight, intelligent planning, sound engineering, continuous research and attention to detail by Thomas designers, engineers and technicians whose experience goes back to the beginning of electronic tube history. From drafting board to shipping platform, only the highest quality production control is evident. Little wonder then that Thomas Photo-tron picture tubes are used by so many major TV set makers. See list of 20 at right of this page.

**Thomas Photo-tron**

Picture tubes are exact original equipment with all these TV set makers:

*Admiral*  
*Kaye-Halbart*  
*Bendix Television*  
*Olympic*  
*Meck*  
*Packard Bell*  
**PILOT**  
*Magnavox*  
*Starrett*  
*Calbest*



*hallicrafters*

*Tele-tone*

**CROSLEY**

*Lyon & Healy*

*Tele King*

*Motorola*

**Hoffman**

*Westinghouse*

*Imperial*

**SCOTT**

**Thomas** ELECTRONICS, Inc.  
PASSAIC, N. J.



# TELEVISION ENGINEERING

LEWIS WINNER, Editor

May, 1951

**Plan for More VHF Stations**—Declaring that the FCC's national television allocation plan is not as efficient as it should be in the utilization of the available spectrum space, and in addition, noting that the proposal would foster network and market monopolies, DuMont has countered with a scheme which they feel will provide an increase of 98 *vhf* stations and an increase of 33 communities which can be served by the veryhighs. In other words, they say that it should be possible to assign 655 stations in 375 communities, as compared to FCC's 557 assignments in 342 communities.

Specifically, the Dumont suggestion would allocate in the top 100 population centers, four or more *vhf* stations to 47 communities, as against only 18 by the FCC, and in the top 50 population centers, four or more stations would be allocated to 31 communities, as compared to only 15 by FCC. Revisions are also recommended for the top 25 population centers, with four or more stations being allotted to the 21 or more communities, as compared with 11 suggested by FCC.

An increase of 61 stations for the ultrahigh bands is also proposed in the plan.

The famous automatic computing machine at M.I.T., *Whirlwind I*, has been cited by DuMont as a means of solving the allocation problem. They feel that if the entire problem of distributing ultrahigh channels across the nation is fed into this automatic computer, a plan devoid of human errors and guesswork might result. Sample data have already been fed into the machine and more will be introduced, and with the FCC's permission, results submitted during the hearings. It'll be interesting to see what this automatic thinker offers. Maybe the FCC will have to move to Cambridge and conduct its hearings there, hereafter.

**A Broadcaster's Dissenting VHF View**—According to WHEC's chief engineer, Bernard O'Brien, the present *vhf* channels should be able to accommodate many more stations than are now proposed. In his opinion, if the propagation curves now contained in the proposed engineering standards are not modified substantially by future experience, the range of all existing *vhf* stations will be in the neighborhood of 50 miles. Doubling the number of *vhf* assignments, he felt, would reduce the figure to about 35 miles; probably four times as many *vhf* stations could be accommodated, with a probable range of 25 miles or so. O'Brien said that he was sure that most of those operating AM stations, on a regional or local frequency, would be

very happy if they could cover a 25-mile range at night. In the '48 plan, there were provisions for 953 stations on the 12 channels. O'Brien expected that eventually we should be able to equal or exceed this figure.

**Theatre TV Spurts**—According to a report from RCA, thirteen of the largest motion-picture exhibitors have placed orders for large-screen instantaneous TV installations.

Only about a year ago the movieland officials completely discounted the need for TV in the cinema palaces. Today, the flicker exhibitors have bluntly admitted that TV has become a *must* feature in movie houses.

**Washington's Interest in Theatre TV**—Theatre TV will be spotlighted in Washington during September when the FCC will hold fact-finding meetings to determine whether existing and proposed transmission requirements can be satisfied by existing or additional wire or fixed station facilities. The session will also survey the possibilities of special frequencies for an exclusive theatre TV service, and the media which might be used to provide such a service: *rf*, coax or wire for intracity or intercity transmission.

### **Needed . . . An Equalized Military Production Plan**

The present rearmament program has created a very disturbing aspect . . . uneven distribution of the military load. Many manufacturers are in the danger of being caught in a squeeze between material shortages on one hand and insufficient or no military orders on the other. RTMA board chairman, Robert C. Sprague, declared during the recent AFCA convention that . . . "This condition might not be alarming were it not for the recognized essentiality of electronics to modern warfare."

"Because of the importance of electronics to our national defense," he pointed out, "it is dangerous to permit any significant numbers of manufacturers of end equipment or components to fall by the wayside."

Manpower was also cited as an acute problem in the unbalanced production scheduling program now in force. Sprague declared that when a plant is forced to curtail its production, its skilled manpower is apt to be lost to industry and to our defense program.

It is imperative that this thorny situation be adjusted quickly, to insure an equitable scale of production which will be of material benefit to the military and civilian economy.—L. W.

### The Defense Program and Production

**No Victory-Line Parts, Please:** Strong opposition to any so-called *Victory-Line* of components has been voiced by the task group of the Electronic Parts and Component Distributors Industry Advisory Committee, in a repair-parts program report, recently filed in Washington. The committee, composed of Hoyt Crabtree, Joseph De Mambro, William Harrison, W. D. Jenkins and Arthur C. Stallman, indicated that they soundly approved the simplification of every line of material used in the maintenance and repair of electronic equipment, but were strongly opposed to any *Victory-Line* of the type produced during the last war. These parts were described as of very little value and extremely wasteful of materials. In general they were found to be larger, heavier and more irregular in size than the standard replacement parts and thus used much more material than a standard part.

The report, prepared at the request of NPA, also declared that since the total tonnage of critical materials required for replacement parts, is quite small compared to some of the heavy industry requirements, as structural members which use the greatest poundage are not usually replaced, the various raw material divisions of NPA should allocate sufficient raw materials for such components. Specifically, they said, parts makers should be in a position to make at least 150% of the number of units sold for replacement purposes, using '50 as a base year. The group felt that the phenomenal increase in production of TV sets during the last six months of '50 (for which replacement requirements will not be apparent until several months) will make it imperative to adopt the suggested 50%-increase production plan.

**Nickel For Tubes:** NPA has announced that the receiving tube industry will receive during May 200,000 pounds of nickel and during June, 180,000 pounds.

Industry had set, as a sliding scale of minimum requirements for nickel, 250,000 pounds for May, 225,000 pounds in June and 200,000 pounds for July. Cuts below these figures, it was said, would jeopardize the industry and weaken its capacity for defense orders.

Pointing out that while these figures represent a reduction

in the *minimum nickel requirements* stated by the Receiving Tube Industry Advisory Committee, NPA declared that, in view of the increasing scarcity of nickel and the substantial conservation programs of the industry, these quantities are considered adequate to permit operation on a minimum basis.

Under the industry's normal cycle of operations, NPA noted, nickel made available in May and June will not result in the production of receiving tubes for several months, when military requirements will have increased substantially.

According to NPA, assurance had been given by the tube industry that adequate quantities of receiving tubes would be channeled to the replacement market through tube distributors. Receiving tubes for new home sets will be available only after all other needs have been met.

**The CMP Plan:** On July 1 the Controlled Materials Plan for defense and defense-supporting production will go into operation. It will be patterned after the World War II CMP plan, but with one important exception, the total supply of steel, copper and aluminum will not be controlled. Civilian consumption will take a large share of these metals and this consumption will be regulated not by *CMP*, but by *NPA* limitation orders.

Under the present priority system, we have actually been drawing checks on the bank without knowing exactly how many checks are out, or even knowing the exact bank balance.

Under *CMP* there'll be available information which will disclose how much of the yardstick materials—steel, copper and aluminum—will be available during a given quarter. It will then be possible to determine how much of this supply can be allocated to each defense and defense-supporting program. With these determinations, government then will know how much will be available for civilian consumption.

Generally conceded by government and business alike is the fact that *CMP* will not be a very efficient operation during the third quarter of this year. In fact, it will take some months to get it in full operation. But, it is felt that with *CMP* in operation, there will be the machinery to cope immediately with any emergency.

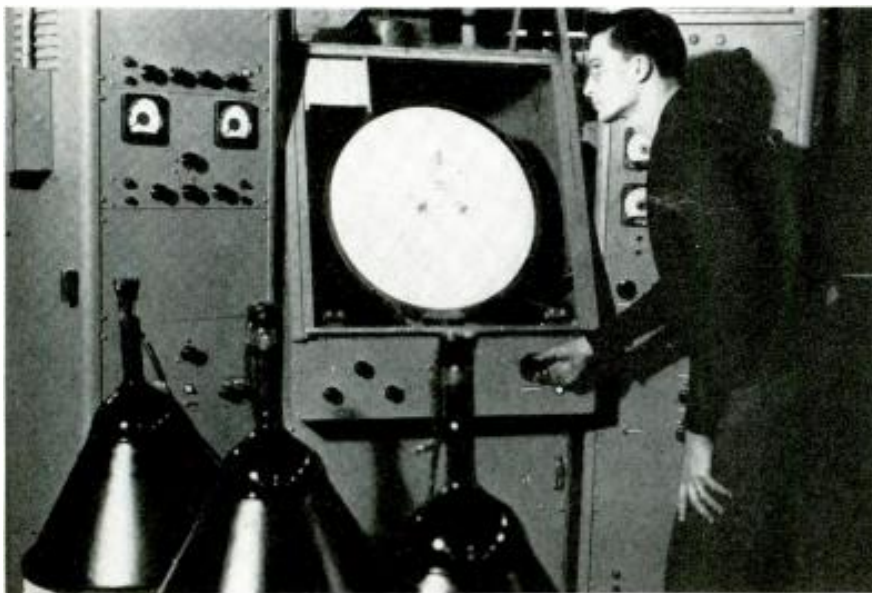

Left: Quality control testing of 19-inch metal picture tubes. Below: Germanium crystal contour projector. Whisker and pellet assemblies for a germanium diode can be inspected at a magnification of 20 times with this projector. Equipment can also be used to study surface details of germanium crystals.

(Courtesy G.E.)

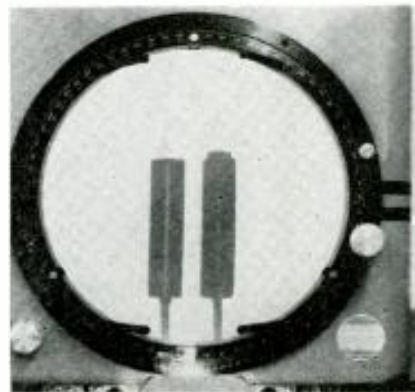

### New Materials

**Glass Fiber Filter Paper:** A filter paper made entirely from glass fibers that is claimed to be 5,000 times more effective than commercially available filters has been produced by the Naval Research Lab.

For dielectric application, the glass fiber paper is said to provide one answer to the military and industrial design problem of making electronic equipment smaller that will at the same time stand higher operating temperatures and have longer operating life. Although there are synthetic insulating oils capable of withstanding operating temperatures in the range of 125° to 200° C, kraft paper, cites NRL, cannot stand up under these temperatures and consequently the top operating temperature of capacitors is 85° C. The glass fiber paper removes this temperature limitation, and since it is thinner than kraft paper (individual fibers have an average diameter of 6 millionths of an inch, or about 1/20 the thickness of a human hair) it will also permit making smaller capacitors.

The manufacture of this filter paper is described as closely resembling conventional paper-making. Glass fiber is added to water in a paper beater, the stock is circulated for a short time and then dumped into a chest from which it is pumped to a standard Fourdrinier paper machine. In a recent run at the National Bureau of Standards, the machine was able to run at a speed of 28 feet per minute to produce a paper one one-hundredth of an inch thick.

### Fabrication Techniques

**Glass-to-Metal Solder:\*\*** Metal can now be soldered to glass, or ceramics and carbon according to a new technique. The glass and metal areas to be soldered are painted with a thin layer of titanium hydride, and solder is placed upon both painted areas. The parts are placed together and then heated under a vacuum.

When the temperature reaches about 900 F, the titanium hydride decomposes. This causes the solder which has already become molten, to adhere to the titanium-painted areas of both glass and metal. A strong, tight bond is said to be formed upon cooling.

\*\*G.E.

Below, left: Schematic of grid-lathe grid winding process. Length of grid is pulled off the mandrel (M) in the direction of the arrow. Support wires (S) run in two grooves in this mandrel, the cross section of which normally determines the size and profile of the grid. During the rotation of the mandrel a notch is cut in each support wire in turn at the required pitch by the cutting wheel (C). Then the winding wire (L) is fed into the notch and during the next revolution of the mandrel, is swaged into the support by the action of the swaging wheel (W). The lateral motion of the strip is obtained from a lead screw, but the pitch can be varied at any one point along the grid by means of a cam, which controls the position of the leadscrew. The grids are wound in lengths of approximately 10" to 12", determined by the length of movement of the drawbar on the leadscrew, subsequently cropped into individual grids and where necessary stretched or pressed to their final profile.

At right is the grid lathe in operation.  
(Courtesy Standard Telephones and Cables, Ltd.)

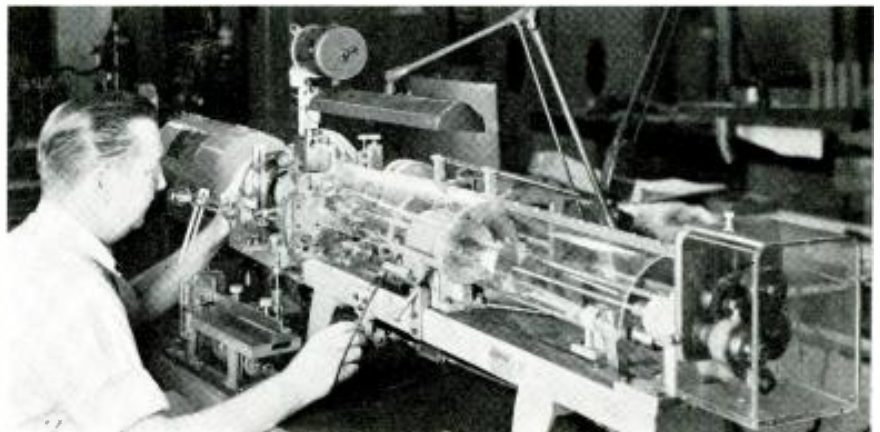
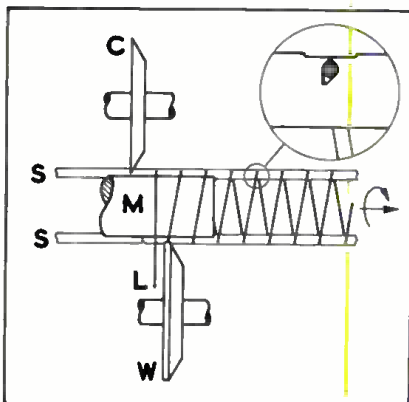

### Tube Production Equipment

**Grid-Winding Lathe:\*** A grid lathe designed to produce more turns to the inch, and also provide a sure method of strip-cutting to eliminate the spring-back of support wires when cut, to increase the accuracy of grid lengths, has been developed.

The lathe can produce all types of grids used in standard, miniature and subminiature tubes. Machine is said to have a degree of accuracy of  $\pm 0.001$  overall on a 10-12" strip. Using the notch and swage method, the machine is capable of producing 300-1000 grids per hour, depending upon the grid pitch.

The swaging and staking arms, holding respectively the swaging wheel and staking tool, can be set to the correct helix angle, thus avoiding drag. A lateral adjustment can be applied independently to each to insure the stakes being accurately positioned on the grid legs.

A gripper and strip cutter clamps the strip on the main spindle side of the cutting position and is not released until the wires are re-clipped and the half-nuts engaged again ready for the next run. Thus, the tension on the uncut portion is not relaxed at any time. All the gaps between the grids can therefore be accurately maintained to the same length. A safety lock is provided which makes it impossible to run the machine with the gripper closed. The strip cutter is foot operated and the whole sub-assembly is micro-adjustable laterally and slides in a keyway in the machine bed.

Tension on the winding wire is controlled by an electromagnetic brake, the wire spool being mounted on the spindle of a fractional hp single-phase squirrel-cage motor, the field of which is fed by a continuously variable dc voltage. The wire is guided into the notches on the support wires by a universal wire guide, which is suitable for both constant and variable pitch winding.

Mechanism is also provided for burning out the loose turns between individual grids on the stick as it is being wound. This consists of two chisel-shaped electrodes, which are fed with dc voltage obtained through a selenium rectifier unit.

\*Brimar Grid Lathe; Standard Telephone and Cables, Ltd., affiliate of I. T. & T.

## Tube Activities

**Subminiatures:** With space and weight limitations set as a basic requirement in the bulk of projects on the lab bench, it has become imperative to survey all types of smaller and smaller items. The subminiature tube has been particularly prominent in these studies, because of its many unique virtues.

Reviewing these characteristics at a components-reliability meeting at U.C.L.A. on the Pacific Coast, R. E. Graham of Sylvania noted that the tubes now feature oval cathodes in place of the cylindrical cathode. This design permits the use of a shorter length to obtain the same amount of cathode area, thus achieving a cathode and mount structure more resistant to shock. The oval cathode was also described as making possible the use of tungsten lateral wire in oval unformed grids, which means that smaller diameter wires and higher pitches can be utilized to achieve a higher ratio of  $G_m$  per mil of plate current. In addition, it was disclosed, the resulting mount configuration with oval cathodes and grids achieves shorter and more uniform electron transit time, thus contributing to improved performance at high frequencies.

Graham pointed out that the inherent advantages of subminiature tubes for  $hf$  operation result from short mount structures and short lead lengths to the mount, both of which contribute to lower inductances and inter-electrode capacitances. In addition, the use of wafer-type headers also contribute to lower capacitances, since the minimum thickness of glass in the seal reduces the effect of the dielectric factor between leads. A tripod support of mount structures has been adapted for high frequency use, it was revealed, to avoid duplication of leads into the header which would raise capacitances. Since only one plate connection is permissible on pentode types, if grid-plate capacitance is to be kept low, plate structures have been redesigned to use tab connections to the mica; the tripod support is used to provide three cathode connections which increase input resistance and permit separate input and output returns. On triode types, Graham said, the tripod structure comprises one plate connection and two dummy insulated leads, since the elimination of two extra plate leads is desired to improve the ratio of input to output capacitance.

Describing problems of temperature, the Sylvania specialist said that even under ordinary operating conditions, the bulb

temperature of subminiature tubes is considerably higher than that of similar tubes of larger size, due to the dissipation of equal amounts of energy within the smaller space. The operation of tubes at the high ambient temperatures generated in compact equipments further increases bulb temperatures, and a point is finally reached, he indicated, where the glass (Corning G12) conventionally used in tube manufacture is no longer satisfactory for lead seals. The effects of prolonged tube operation at high ambient temperatures were said to have been found to be a destruction of the lead wire seals due to electrolysis, and a slow evolution of gas which produces a gradual deterioration of cathode activity. To minimize the adverse effects of high ambient temperatures, a specially-processed low-electrolysis glass is used for both headers and bulbs of all premium subminiature types. Tendency toward electrolysis in the lead seal is further reduced, Graham added, by the wider lead spacing of the circular pin arrangement of the base, which produces a better strain pattern in the glass, thus increasing resistivity.

Covering application problems, Graham declared that circuits should be so designed that each type is used only for the purpose for which it is intended and only within the rated limits of voltages and currents. In addition, consideration should be given to the incorporation of heat removal techniques in compact units, in order that maximum bulb temperatures will not be exceeded. Care must also be taken in mounting tubes, whether leads are soldered to circuit components or subminiature sockets are used. Where tubes are to be subjected to severe shock and vibration, the bulb must be supported firmly by a shield or a clamp.

**Wide-Band Amplifier:** A secondary-emission, wide-band amplifier tube\* having a transconductance of 25,000 micromhos designed for use at frequencies up to 200 mc, has been developed for a standard T-6½ miniature envelope, utilizing a 9-pin base. The tube has been described as useful as a square-wave generator, providing rise times on the order of  $5 \times 10^{-8}$  seconds. In a three-stage stagger-tuned 100-mc amplifier having a 20-mc bandwidth, the tube is said to provide an overall voltage gain of 1200 as compared with 47 for the 6AK5.

\*N. U. 5857.

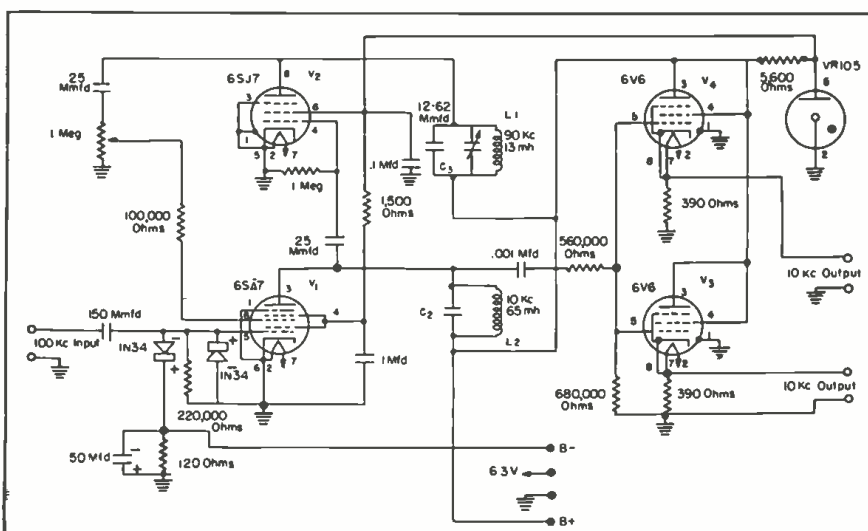

Left: A 10 to 100-kc regenerative frequency divider, developed by NRL which provides improved stability. The divider will operate with plate voltages ranging from 40 to more than 350 and at the same time the input can vary from one or two volts to more than 45. Below: An *afc* box developed by the Signal Corps Engineering Labs.

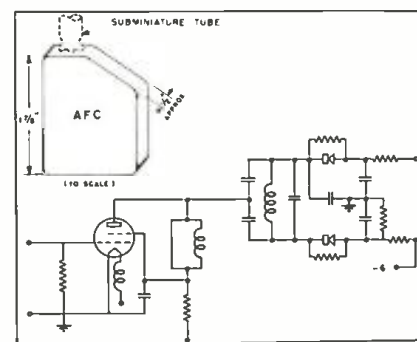



Theatre TV

**Random Noise:** Theatre TV, which is destined to become quite a factor in the video art, will require a definitive evaluation of many facets of the medium, such as the random noise which is permissible with the equipment used. Analyzing this factor at the recent annual SMPTE meeting in N. Y., Pierre Mertz of Bell Labs declared that in the meantime certain deductions can be drawn from other sources to permit the estimate of a provisional figure which can eventually be checked.

In the first place, he said, we can examine data which have been obtained for the setting of random noise requirements for 4-mc broadcast television. Though the solution of this problem is not definitive either, experience with it has indicated that the present best simple answer consists in weighting the frequency distribution of the random noise, and measuring the *rms* amplitude of the weighted noise wave, as compared with the peak-to-peak amplitude of the television video signal (from tip of synchronizing pulse to maximum white level). In this instance, the effect of varying amounts of weighted noise upon a picture is submitted for judgment to a group of observers.

A study of a theatre television picture, obtained from an 8-mc band without increasing the number of lines above 525, has indicated, according to Mertz, that the same weighting function is to be used as for broadcast television, i.e., curve I of Figure 2. However, the requirement is to be made more severe by 3 db.

This figure, or the viewing of the picture at a closer range, is an estimate of the influence of the higher quality of the 8-mc theatre television image (in the form of increased sharpness as compared with a 4-mc image).

Another estimate of permissible random noise in theatre television pictures can be deduced from a study of the photographic graininess in present day motion pictures. Although this graininess is perceptible to a watchful observer in a good seat, it is not obtrusive and not considered a problem by the motion picture industry. It can therefore serve as an index of how much of this impairment is acceptable.

A simple deduction on the amount of this noise as derived from sound track measurements appears in table A. Describing these data, Mertz said that this table indicates a weighted signal-to-noise ratio, in television terms, of 47 to 52 db.

A third check which can be made against these figures,

Figures 1 (right) and 2 (below) Figure 1 shows the characterization of random noise on a TV image. Weighting functions and random noise distributions appear in plot below

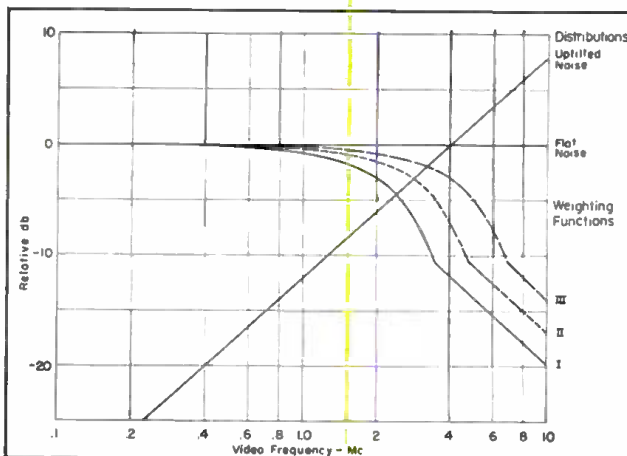

noted Mertz, is the random noise being delivered by camera tubes at present available. The performance of these, of course, varies a great deal with the conditions of use, the adjustments, and the individual tube being used.

The indications from this third check as a whole are, therefore, that for theatre television the random noise will be a problem not only for the connecting links, but also for the pickup apparatus.

Sound track noise (variable density)	
Optimum	45 db, with corrections, 52.4 db
Typical	40 db, with corrections, 47.4 db
Corrections	
Sound signal: rms to peak-to-zero .....	+ 3 db
peak-to-zero to peak-to-peak .....	+ 6
margin over peak-to-peak 50% to 80% transmission range .....	+ 4
Aperture: 84 square mils (sound track) to 1.32 square mils (television) .....	- 18
Repetition rate, 24/30 .....	- 1
Synchronizing signal added..	+ 2.5
Noise weighting (curve III)..	+ 2.9
Net correction .....	+ 7.4 db

Table A Deduction on amount of random noise from sound track measurements.

Camera tube	Signal, peak-to-peak, including sync to weighted noise
1850-A iconoscope ...	44 db
5655 image orthicon	44 db
5769 image orthicon	below above figure
5820 image orthicon	40 db
5826 image orthicon	43 db
1818 iconoscope ...	39 db
2P23 image orthicon	36 db

Table B Signal-to-noise figures for standard camera tubes.

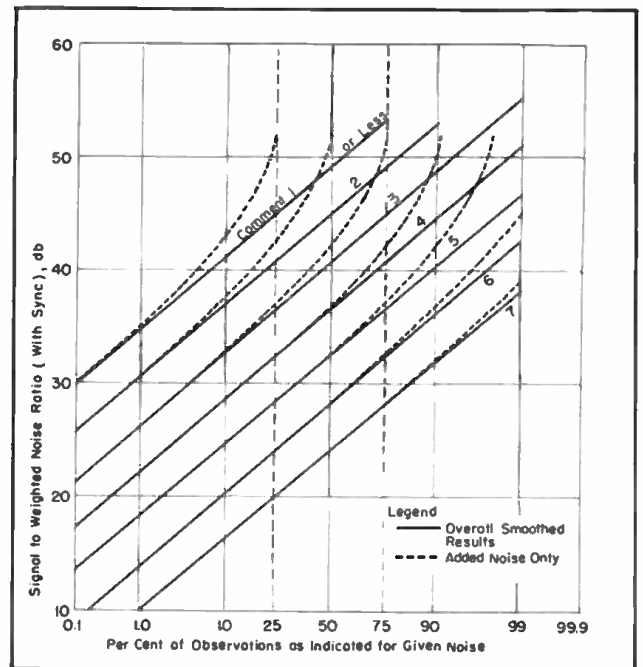

Video System Design

**The Gray Scale:** In developing any system, it is prudent to adopt an ideal goal. In TV such a goal has been described as a media which will permit reproduction of scenes in front of the camera so perfectly that they could not be distinguished by visual means from the original, even though the original had the physical properties of three dimensions or depth, color and life size. In an interpretation of these qualities at the SMPTE New York convention, Fred G. Albin, of ABC on the Pacific Coast, declared that a system, to be ideal within the established limits, must be free from distortion of gray-scale brightness, distortion, of contrast versus frequency characteristics, and free from noise and spurious signals. In addition, it was said, the limitation of brightness range, contrast resolution and other physical and optical properties of the system should be defined only by the reproducing tube.

Specifically, noted Albin, the physical factors which determine video-system performance are:

**Brightness;** the term for life flux per unit area emitted from the subject or from the image. This is a measure of magnitude, its counterpart in the electrical circuits being electrical wave amplitude measured in volts, which varies directly with *gain*.

**Contrast;** a ratio of brightnesses of either the subject or image. Contrast of the image is the combined effect of the optical properties of the subject and the gamma of the video system which has transmitted the video information to the image.

**Gamma;** the parameter of a video system characteristic which affects or controls contrast of the reproduced image as a function of brightness.

**Resolution,** or frequency characteristic; the relation of image contrast to image detail frequency when the frequency alone is varied.

**Noise;** the disturbance to the instantaneous brightnesses of detail of the image due to graininess or spurious electrical signals from thermal agitation, etc.

Reviewing the problem of subject brightness, Albin said that this characteristic is the product of surface reflectivity and the illumination thereof, under the Lambert cosine law of directivity. The surface texture of a subject to be photographed is a factor controlling effective brightness. Details of subjects to be photographed were said to be distinguished by differences

in physical or optical properties: Density or reflectances, specularly or diffusion of reflectances, and shape or relief from a flat plane. Proper control of these factors must be exercised to reproduce the gray scale properly.

Eighteen items have been found to affect directly brightness:

- (1) Illumination of subject-intensity, direction, color (primary variable);
- (2) reflectivity of subject (primary variable);
- (3) camera lens speed (adjustment);
- (4) camera pickup tube response sensitivity (fixed);
- (5) electrical gain of video signal (chief control);
- (6) picture reproducing tube response sensitivity (fixed);
- (7) recording camera lens speed (fixed);
- (8) photographic film speed under these conditions (fixed);
- (9) positive film printing light actinic intensity (control);
- (10) positive film speed (fixed);
- (11) projector illuminant (fixed);
- (12) projector lens speed (fixed);
- (13) film pickup camera tube response sensitivity (controllable);
- (14) electrical gain of video signal (chief control);
- (15) radio transmitter radiated field strength (fixed);
- (16) radio propagation factors (variable);
- (17) receiver sensitivity and gain (chief control) and
- (18) picture reproducing tube response sensitivity (fixed).

(Those items identified as *variable* were noted as involuntarily from the standpoint of the video control operator; those identified as *controls* are used to counteract the variables.)

Evaluating brightness distortion, Albin said that it prevails from several sources in the system, indicated as a variation of gamma from both unity and constancy. The trend is always toward loss of gamma at the extremes of the contrast range. It was pointed out that a counteracting characteristic should be incorporated in each block where distortion prevails, or least in a lumped form in each system by a gamma correcting network. One of the larger sources of distortion is the iconoscope which compresses the while levels. Correction of this condition would give beneficial improvements.

Declaring that since the gamma is inconstant, the ABC representative said that greater efforts should be made to maintain constant brightness levels in the system, and correct for variations at the source of the variations. Thus, the chief compensator for scene brightness variation should be the lights or the lens iris, and not gain control on the output of the camera.

Circuits of 6AK5 and 5857 stagger-tuned triplet systems, above and below: see p. 6 for design highlights of 5857.

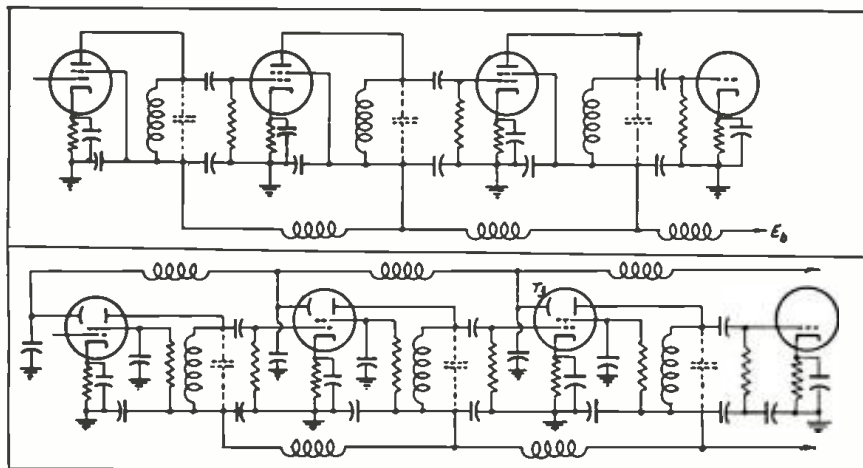

A glass-type midget trimmer capacitor, the characteristics of which are described by Ralph Peters, in this issue, in his article on New Trends in Component Design.

(Courtesy Corning Glass)

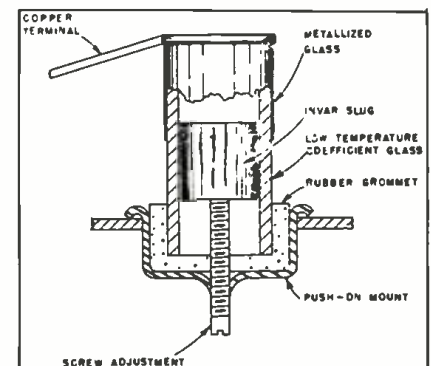

**New Posts:** *Charles E. Krampf*, president of Electrical Re-actance Corp., has been elected executive vice president of Aerovox Corp. He succeeds *Bert Conway* who has resigned, but will remain with Aerovox on a consulting basis and as a member of the board of directors. . . . *W. B. Whalley*, engineering specialist for Sylvania Electric Products Inc., has been appointed adjunct professor in electrical engineering for the Polytechnic Institute of Brooklyn. Whalley was formerly with Cornell as an assistant professor of engineering physics. . . . *Charles L. Cade*, formerly sales manager of Eastern Engineering and Sales, Philadelphia, has been named director of distributor sales for Sarkes Tarzian, Inc. . . . *R. V. Bontecou* is now product manager, tube division, of General Electric, and will be in general charge of product planning and market research. . . . *Robert L. Werner*, formerly special assistant to the Attorney General of the United States, has been elected general attorney of RCA, succeeding *Joseph Helfernon*, who is now financial vp at NBC. . . . *C. W. Michaels* has been appointed supervisor of market research for the G.E. commercial equipment division. . . . *Edward K. Foster*, general manager of the Bendix radio communications division, has been elected a vice president and member of the administration committee of Bendix Aviation. . . . *Louis C. Kunz*, formerly section engineer on cathode-ray tubes, has been appointed product manager for cathode-ray tubes in the General Electric tube divisions. . . . *J. J. Farrell* has become assistant manager of engineering, and *L. H. Junken* has been named division engineer of engineering services of the commercial equipment division of General Electric. . . . *H. B. Fancher* has been appointed division engineer of commercial products for General Electric's commercial equipment division. . . . *Curtis B. Plummer*, present chief engineer of the FCC, will head a new *Broadcast Bureau* of the Commission. This new bureau will consist of an *Office of the Chief* and five divisions: *Aural Facilities Division, Television Facilities Division, Renewal and Transfer Division, Hearing Division, and Rules and Standard Division.* The Broadcast Bureau will unify work pertaining to radio broadcasting which has heretofore been handled by various legal, accounting and engineering units within the Commission. This will mean the abolishment of the separate broadcast divisions now under the general counsel, chief accountant and chief engineer, and the transfer of their personnel to the new bureau. The effect will be that a single broadcast bureau, under its chief, will be responsible to the Commission for discharging legal, accounting and engineering functions in connection with all broadcast services. . . . *T. J. Falk* is now supervisor of technical publications for the G. E. receiver division. . . . *Theodore Lindenberg*, formerly in charge of engineering of the instrument and disc recording division of Fairchild Recording, has been named chief design engineer of Pickering and Co., Oceanside, Long Island. . . . *Dr. Mervin J. Kelly*, formerly executive vice president of Bell Telephone Laboratories, has been elected president, to succeed *Dr. Oliver E. Buckley*, who has accepted an appointment by President Truman as chairman of the newly created Science

Advisory Committee of the Office of Defense Mobilization. *Dr. Buckley* has been elected chairman of the board of the Laboratories. . . . *Frederick F. Sylvester* has been appointed to the staff of General Ceramics and Steatite Corp., Keasbey, N. J. Sylvester, who previously was sales manager of the Engineered Products Division of Air Associates, Inc., will serve as assistant to Christopher L. Snyder, vice president in charge of sales. . . . *Robert E. Burrows*, formerly with Meissner Manufacturing Division of Maguire Industries, Inc., as general sales and advertising manager, is now general sales manager of Thomas Electronics, Inc., Passaic, N. J. . . . *Edward F. Harbison* is now manager of the Pacific Coast government and industrial division of Philco, with an office in Beverly Hills, California. Harbison has been chief of the Guided Missiles Plans branch of the Air Material Command, Wright Field, Dayton. . . . *Joseph H. Gillies* has been named vice president-operations of the Philco government and industrial division. He will also continue to act as vice president-operations of the Philco TV and radio division. . . . *William J. Peltz* has been appointed manager of operations in the government and industrial division. In this capacity, he will report to Gillies and will head all staff and manufacturing functions of the division. . . . *Robert F. Herr*, Philco vice president, is now on the president's staff and will direct all government and industrial sales and contract negotiations. . . . *James D. McLean* has been appointed general sales manager of the Philco government and industrial division, reporting to Herr. . . . *Bill C. Scales* has been appointed general sales manager of the crt division of Allen B. DuMont Labs.

**Washington Assignments:** Now serving on the NPA receiving tube industry advisory committee are: *J. M. Lang*, G. E.; *J. Q. Adams*, Hytron; *W. J. Peltz*, Philco; *K. C. Meinken*, National Union; *Carl Hollatz*, RCA; *N. B. Krim*, Raytheon; *R. E. Carlson*, Tung-Sol; and *R. F. Marlin*, Sylvania Elec. . . . On another NPA committee, the electronics products end-equipment group, there are twelve representatives of industry: *R. Siragusa*, Admiral; *C. W. Thompson*, Arvin Industries; *J. W. Craig*, Crosley; *H. C. Roemer*, Federal Tel. and Radio; *W. J. Halligan*, Hallicrafters; *Dr. W. R. G. Baker*, G.E.; *Adolphe A. Juviler*, Olympic; *Franklin Lamb*, Tele-King; *J. B. Elliott*, RCA; *Ray C. Ellis*, Raytheon; *R. Alexander*, Wells-Gardner; and *Fred Lack*, W. E. . . . On a third NPA advisory committee for electronic components, are: *W. E. Wilson*, Acme Electric; *George Biley*, Biley Electric; *A. D. Plamondon*, Indiana Steel; *Harry Ehle*, IRC; *A. P. Hirsh*, Micamold; *L. F. Muter*, Muter Co.; *W. R. Reisner*, Reisner Manufacturing Co.; *Sarkes Tarzian*; *R. S. Sprague*, Sprague Electric; *J. J. Kahn*, Stancor; *Max Balcom*, Sylvania; *C. E. Williams*, DuMont; and *R. F. Sparrow*, P. R. Mallory. . . . *Neal McNaughten*, director of the NARTB department of engineering will soon leave on the SS America for a six-weeks stay in Geneva, Switzerland, as a member of the U. S. Delegation to the Sixth Plenary Assembly of the CCIR (International Radio Consultative Committee) and also as International Chairman of the Study Group on Broadcasting.

C. E. Krampf

W. B. Whalley

T. Lindenberg

R. E. Burrows

Bill C. Scales

M. J. Kelly



# Design Features of

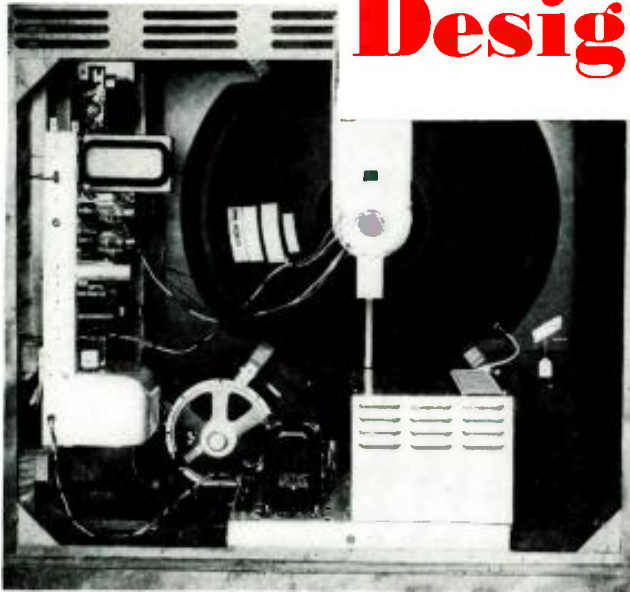

*Analysis of Circuitry and Layout Modifications Required to Provide Satisfactory Results on Picture Tube With 526-Square Inch Viewing Area.*

Figure 1 (Left)

View of chassis with 30-inch tube, which illustrates position of power supply chassis, horizontally mounted directly under picture tube, and main chassis, vertically mounted at the left.

Figure 2 (Right)

Assembled high-voltage supply chassis. Tubes shown include, from left to right, two 5U4s (low-voltage rectifiers), and a 6SN7 and 6AL5, used in the picture-tube sweep-failure protection circuits.

DIRECT VIEWING, once considered as essentially a small-vision area medium, with little hope for any practical improvement through tube magnification, has certainly witnessed a rout of these beliefs during the past year. From the ten inch, once described as a large type picture tube, the industry has seen a parade of size increases up to 24 and recently to 30 inches, with a tube depth of only 23"; overall length from outermost bulge of the face to the tip of the socket. And there has also been

quite a flow of unusually efficient circuitry systems, evolved to accommodate these larger tubes.

With the advent of the 30-inch affair, chassis designers were faced with a host of problems not only in deflection yokes, but also in sweep supplies, with the horizontal deflection system looming as a major difficulty. To overcome these difficulties, many innovations in design have had to be provided. For

instance, it was found necessary in the development work associated with the high voltage power supply to embody voltage regulation, because it was felt that the peak beam current which reaches 600 microamperes would impose such a burden upon the power supply that defocusing of the beam might result, due to variations in the output voltage of the supply.

The deflection amplifiers also had to be altered; the flyback-high voltage supply was omitted, the horizontal

Figure 3  
Schematic of high-voltage supply.

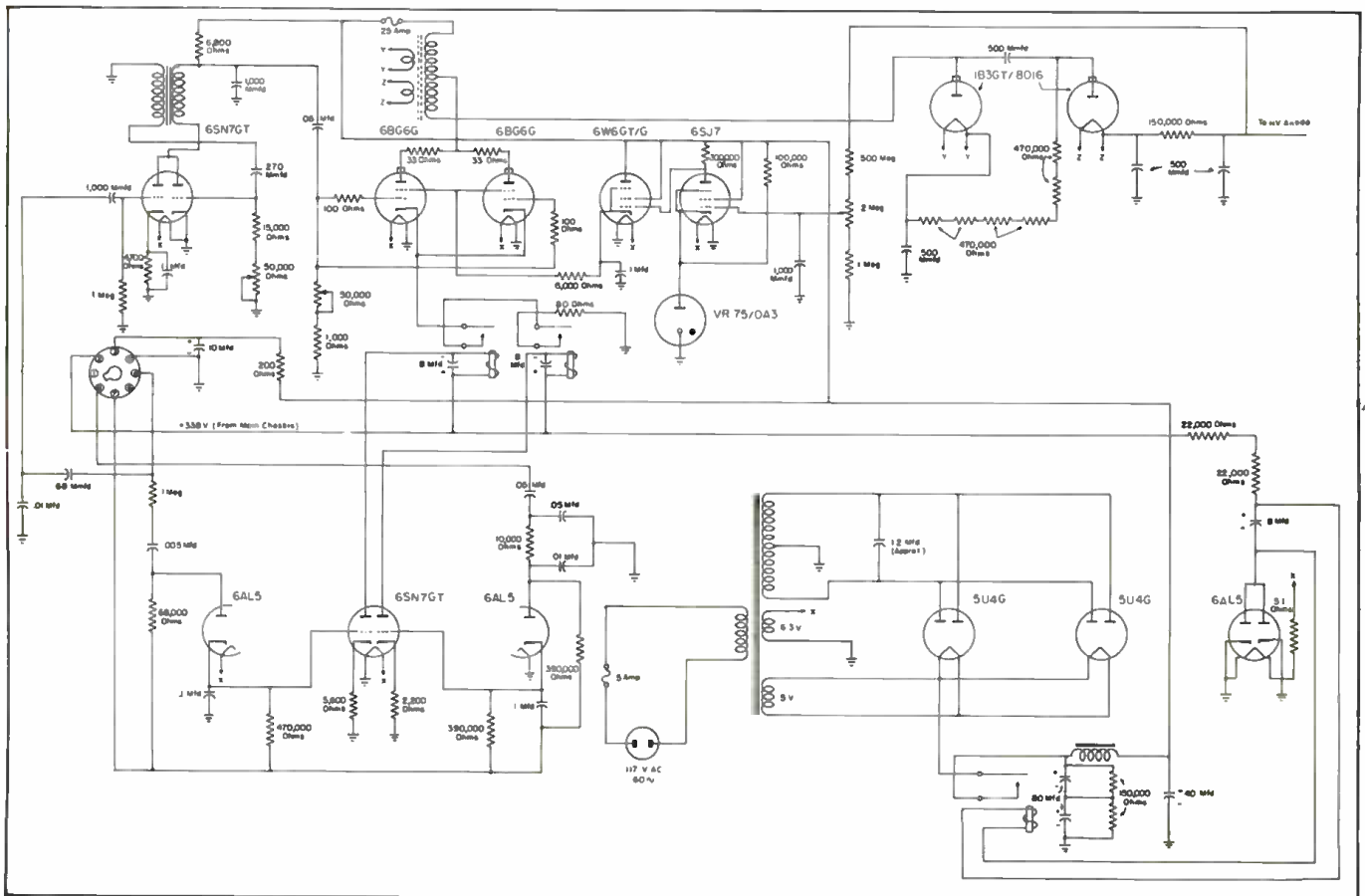

# 30-Inch TV Receiver

by RICARDO MUNIZ

General Manager, Television Receiver Manufacturing Division, Allen B. DuMont Laboratories, Inc.

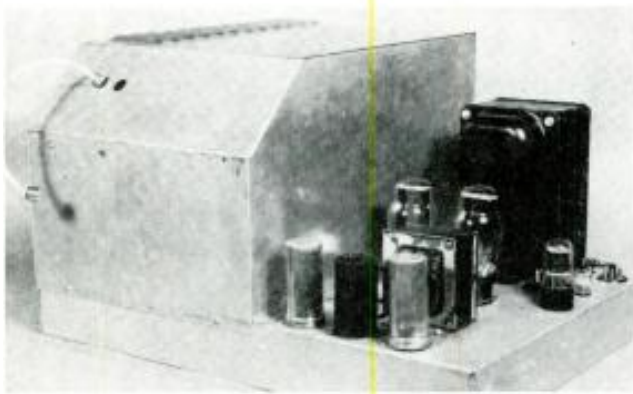

Figure 4 (Right)

High-voltage chassis with protective cover removed. Tubes shown in this view are, from left to right, at rear: one 6SN7 (blocking oscillator); two 6BG6s (hv drivers); one 6W6 (control tube); one 6SJ7 (control amplifier) and one VR75 (voltage regulator). Two tubes visible towards the front of the chassis are 1B3s operating as a voltage doubler.

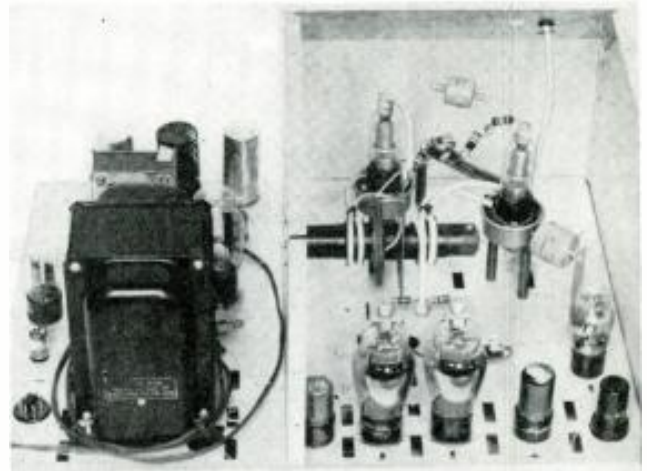

Figure 5

Video if, video detector, video amplifier and picture-tube circuit.

sweep amplifier acting as an amplifier only. For horizontal size control, there was included a variable resistor in series with the screens of the 6BG6s. This is not of the inductor type normally encountered in this chassis. A beam power tube was substituted for the vertical sweep amplifier tube, normally a triode. It was found necessary to provide two vertical linearity controls, one of which could adjust the bias on the tube, while the other controls the screen voltage. The use of these

two adjustments was found to provide good vertical linearity over a very wide range of size control setting. To obtain the additional deflection angle for the 30" tube, additional deflection power was, of course, required from both the vertical and the horizontal deflection amplifiers. An especially designed yoke was necessary to deflect this wide angle without neck cutoff. In use, this yoke

was found to eliminate the pin-cushion distortion effect normally encountered in wide angle deflection yokes, and in addition provide good focus across the whole width of the picture tube. A specially-designed horizontal amplifier output transformer which, of course, does not incorporate a flyback winding, was included to drive the horizontal deflection coil of the deflection yoke. It was found that due to the high peak

(Continued on page 30)

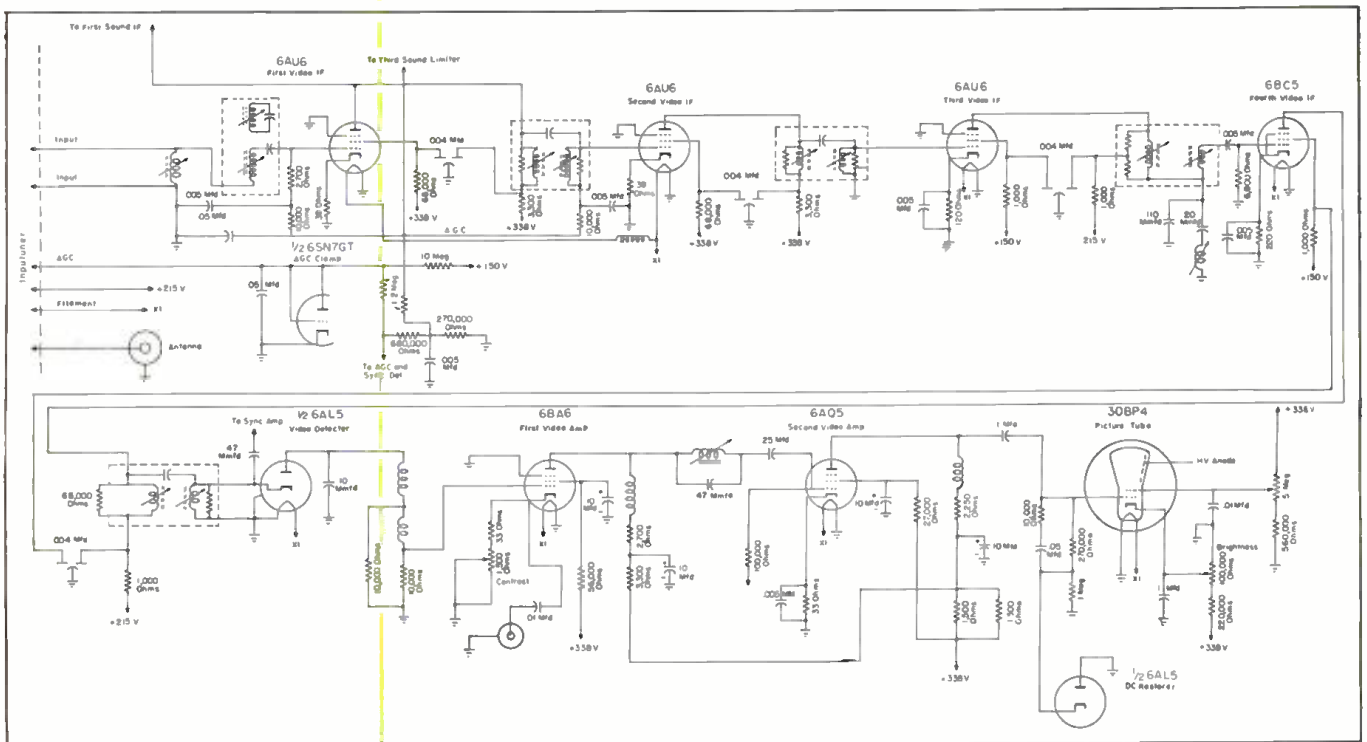

# Horizontal Deflection System Requirements

by JOHN NARRACE,

Project Engineer, Wells-Gardner and Co.

*Discussion of Allied Circuitry and Component Factors Which Should Receive Careful Consideration During Development, Design and Application Stages.*

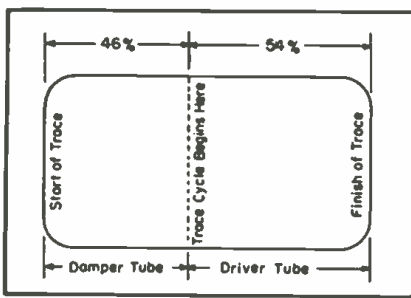

Figure 1  
The visual trace period with its two phases of operation.

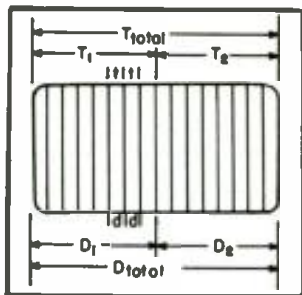
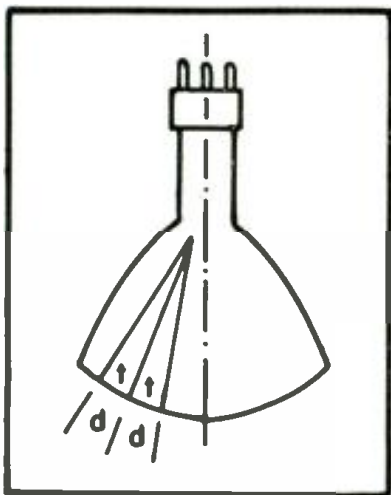

Figure 2  
Relation of time and distance with respect to a displacement of an electron beam on the face of a picture tube.



WITH THE ADVENT of wide-angle requirements, it has become particularly important to include very high-efficiency deflection systems.

The deflection system provides for a trace cycle which begins at approximately 46% of the distance from the left side of the picture tube. The dot produced by the electron beam has to move at a linear rate of change across the face of the tube; that is, for a given instant of time the dot will move a given distance on the picture-tube face. Therefore, if equally spaced vertical lines are drawn across the face of the tube and the face formed a perfect arc, then time would be proportional to distance. Hence  $t = d$ , and if this were consistent during the complete trace, then  $T_1 = KD_1$  and  $T_2 = KD_2$  or  $T_r = KD_r$ . Thus, the rate of change per inch of deflection =  $T_1/D_1$ .

Suppose now we give a specific time to our trace periods. Since the fundamental frequency of the horizontal oscillator is 15.750 cps and time is a

reciprocal of frequency,  $t = \frac{1}{F} =$

$\frac{1}{15.750} = 63.5$  microseconds, and the

full trace period plus retrace period blanking and tolerances = 63.5 microseconds or .0000635 second. After the blanking, tolerances and retrace periods are considered, there is left 54 microseconds of visual trace. Therefore, each line of horizontal deflection has a trace period of 54.0 microseconds.

In Figure 1 the driver tube is shown as operating approximately 54% of the 54-microsecond trace period. The term, *approximately*, is used because actually the transitional point between the damper and driver tubes changes with

Figure 3 (Left)  
Same relationship as Figure 2, but on a perfectly curved surface.

the changes in the  $Q$  of different systems. A lower  $Q$  requires the driver tube to conduct over a larger percentage of the trace, subject to design variations:

54 microseconds  $\times$  54% = 29.2 microseconds (*driver tube*)

54 microseconds  $\times$  46% = 24.8 microseconds (*damper tube*)

The energy is stored in the yoke and transformer during the latter part of trace when the driver tube is conducting, and this same energy content, minus a certain amount due to losses inherent in the system, is utilized for the first portion of trace. This is the basis of the *energy storage* concept. Therefore, it becomes apparent that the driver tube current, or a major portion of it, is used twice.

That there are losses in the system will become obvious if the ceramag core transformer should be replaced with a laminated iron type, or a powdered iron yoke with an iron wire type. A deficiency of deflection will be apparent. It will be found that the portion of the trace will be substantially reduced, as

Figure 4  
Reduction of the deflecting abilities of system due to eddy current losses, etc., thus lowering circuit  $Q$ . A represents point where start of trace would begin if there were no losses. B is actual point of trace start. C represents deficiency of deflection due to losses.

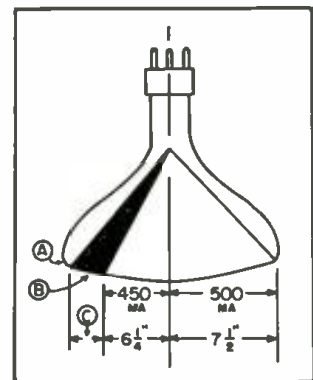

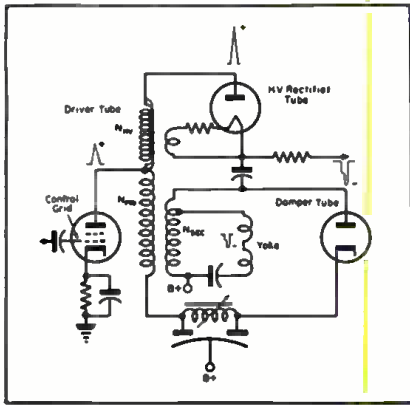

Figure 5  
Functions of the system during completion of the retrace period.

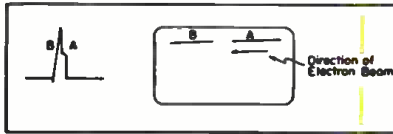

Figure 6  
Relationship of retrace pulse period and displacement of electron beam in the picture tube.

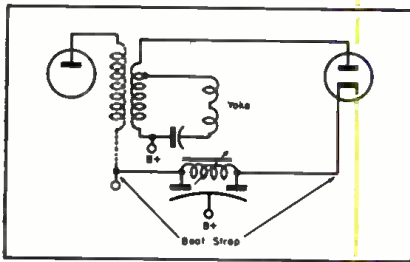

Figure 7  
Equivalent damper circuit, during first portion of trace.

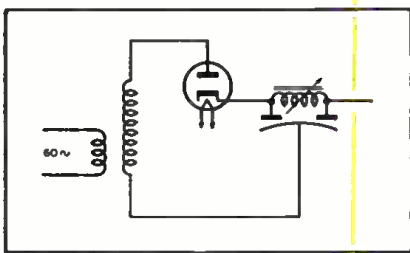
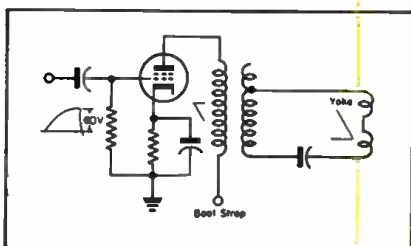

Figure 8  
Basic rectifier circuit.

Figure 9  
The magnification of plate current by transformer action to supply the required yoke current.



shown in Figure 4. According to this illustration there will have been lost 50 milliamperes of current that could have been used for deflection; this current is dissipated in eddy current losses in the iron laminations or iron wire. This represents a lower  $Q$  circuit, inasmuch as it is impossible to recover the energy from the system previously available.

#### Retrace Time or Flybacks

Retrace time is a significant factor in the system. This occurs immediately after the finish of the trace period, or when the electron beam is completely to the right side of the tube. The operation during retrace time is dependent on the capacities of the transformer, yoke, wiring and tubes, and the inductance combination of the yoke and secondary winding of the transformer. These factors form an  $lc$  circuit which resonates between 60,000 and 70,000 cps (8.3 to 7 microseconds) depending upon the parameters of the components of the circuit. Both tubes, the damper and driver are, of course, inoperative during this time. The current that was supplied by the driver tube during the last portion of trace and stored in the form of energy in the yoke and transformer reverses polarity during the half cycle of operation that occurs in the retrace period. This reversal of polarity creates a change in the magnetic flux, which causes a pulse of voltage. This pulse is transformed to the high voltage by the transformer turns ratio:  $E_{hv} = N_{hv} + N_{pri}/N_{sec} = k \times E_{ly}$ , where  $k$  = coefficient of coupling of transformer (usually .95 to .99) and  $E_{ly}$  = amplitude of pulse voltage across yoke. This high voltage is then rectified by the high-voltage tube and applied to the picture tube.

The faster this reversal of polarity (shorter retrace time) the greater the amplitude of the pulse, and also the greater the high voltage for the picture tube. Losses in the transformer, yoke and tubes cause a reduction in the amplitude of the pulse. The reversal of the yoke current through the deflection yoke also causes the electron beam to return to the left side of the picture tube.

During the first portion of a trace, as was previously stated, the stored energy is utilized for deflection. This must occur at a linear rate. The function of the damper tube is to control the rate of decay.

During the first portion of the trace only the secondary portion of the transformer is operating in conjunction with the yoke and damper tube.

From the rectifier circuit the *boost strap* or boost voltage, as it is sometimes called, is obtained and placed in series with the regular supply voltage.

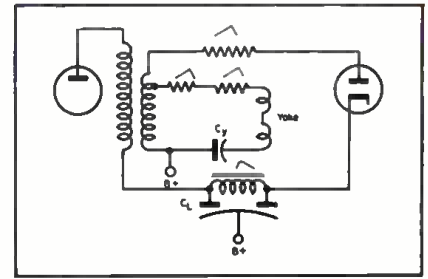

Figure 10  
One of the functions of the linearity control, which can be viewed by placing a scope across linearity control and across a one-ohm resistor, placed in series with the yoke.

Thus, we have a higher  $B+$  available to operate the driver tube and the vertical output tube, if needed.

Reviewing the functions of the circuit, we find, first, that a saw-tooth voltage applied to the grid of the driver tube, causes a saw-tooth of current to flow in the plate circuit of the same tube and hence in the transformer primary. This is then transformed to a greater amount, as required by the yoke, by the transformer-turns ratio.

When the saw-tooth voltage on the grid has reached its maximum amplitude, which is usually between 60-90 volts, peak plate current occurs, and also peak yoke current, which brings the electron beam to the right side of the picture tube. At this time a negative pulse is applied to the driver tube control grid, driving the tube completely into its cutoff region (thus no plate current flows) and the resonant condition in the secondary circuit controls operation during retrace period.

After the completion of this period, during which time the current has reversed and the electron beam returned to the left side of the picture tube, the plate of the damper tube is positive; hence, the tube conducts and terminates any further oscillation on the part of the resonant circuit. At this instant the start of the trace begins. The yoke current begins to decay, and this declination would be at an exponential rate (non-linear), except for the action of the damper tube. This linear reduction of current continues until the electron beam is at approximately the center of the screen. Then the driver tube begins to conduct, repeating the process.

Figure 11  
Equal average currents, as a result of transformer action between driver and damper tube, which also results in equal average currents in yoke:  $i_a$  denotes average current.

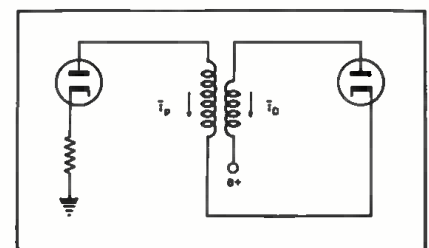

# New Trends in COMPONENT DESIGN\*

Report on Features of New Types of Capacitors and Resistors Now Being Produced for Video and Related Systems

by RALPH G. PETERS

THE DEVELOPMENT OF NEW materials and processes to satisfy the exacting needs of those active in *hf* design has resulted in the production of many unusual components.

At one plant,<sup>1</sup> for instance, there have been produced carbon-film resistors with inorganic binders, which are being evaluated for operation at temperatures of 125° C ambient without derating. (These resistors have been operated at 200° C in sealed form.) On an experimental basis, they are available in various tubular, strip, disc and miscellaneous forms at resistances from 100 ohms to one megohm. A typical miniature unit is a cylinder 1/4" in length and 1/16" in diameter, provided either with standard leads or with tinned ends for direct soldering into printed circuits.

Capacitors developed in this plant have used titanium dioxide, titanates, and fused quartz as dielectric material. Dielectric films as thin as .005" have been found practical from a production standpoint; experimental ceramic films thinner than .001" have also been produced. These developments are significant from both the miniaturization and high temperature aspects of component production. Techniques have been developed for the application of metallized electrodes to the ceramic films and such units are capable of being soldered directly into printed circuits. Spot welding techniques may also be used in some cases to attach leads.

At another plant,<sup>2</sup> glass has been used as a dielectric for capacitors. One

(Continued on page 29)

<sup>1</sup>Balco Research Labs., 580 Market St., Newark 5, N. J. <sup>2</sup>Corning Glass Works.

\*From report on Electronic Equipment Construction, prepared by Stanford Research Institute, and distributed by Office of Technical Services.

Figure 1

Chart with broad quantitative comparisons of general classes of capacitors. According to tests at Stanford Research Institute, the characteristics of titanium dioxide films have been found satisfactory for some applications at temperatures as high as 200° to 300° C.

CAPACITOR TYPE	REMARKS	CAPACITANCE RANGE		TOLERANCE (PER CENT)		DIELECTRIC CONSTANT		VOLTAGE RANGE		TEMP COEFF (PARTS/10 <sup>5</sup> /°C)		TEMP RANGE (CENT.)		DC LEAKAGE RESISTANCE AT 20°C (MEGΩ x MFD)	POWER FACTOR (25°C)			
		MIN	MAX	MIN	MAX	MIN	MAX	MIN	MAX	MIN	MAX	MIN	MAX		1000 CFS	1 MC	100 MC	
Ceramic Capacitors																		
Lead-Boron	Stable; High Temperature	0.6	1000	--	10	4.0	10	500	--	+120	+200	-40	+250	--	0.0008	0.0003	0.0007	
Titanium Dioxide (Titanates)	Stable; Temperature Compensating	5.0	2000	1.0	20	10	100	500	--	+100	-1400	-40	+100	--	0.0015	0.001	0.0006	
Titanates (High Dielect. Const.)	Min Coupling and Bypass Capacitors	500	10000	20	-25	100	18,000	500	--	-15,000	+15,000	-40	+85	100	0.025	0.025	--	
Mica	Stable; Temperature Compensating	MMPD	MFPD	1.0	20	5.7	6.0	300	35,000	-50	+50	-40	+70	10,000	0.0005	--	--	
Glass	Stable; High Temperature (Experimental Units Only)	MMPD	MFPD	--	--	--	8.45	300	30,000	+120	+300	0	+300	10 <sup>7</sup>	--	0.00045	--	
Plastic	Stable	MFD	MFD	1.0	10.0	--	--	500	30,000	500	750	-60	+125	10,000	0.008	--	--	
Electrolytic																		
Aluminum	Limited Use	MFD	MFD	-10	-10	--	--	25	450	+1000	+20,000	-50	+65	1000	0.15	--	--	
Tantalum	Stable; High Temperature	3.5	250	20	--	--	--	15	560	+300	+10,000	-60	+200	100	0.1	--	--	
Paper Capacitors																		
Conventional	General Use	MFD	MFD	5.0	30	--	--	200	1000	+1000	+6000	-50	+70	2000	0.005	--	--	
Metallized	Self-Healing; Miniature	0.0005	10	5.0	30	--	--	150	500	+600	+4000	-50	+70	500	0.01	--	--	
High-Temperature Types	Special Impregnants	0.0005	0.5	5.0	20	--	--	100	1500	+600	+4000	-50	+125	3000	0.015	--	--	



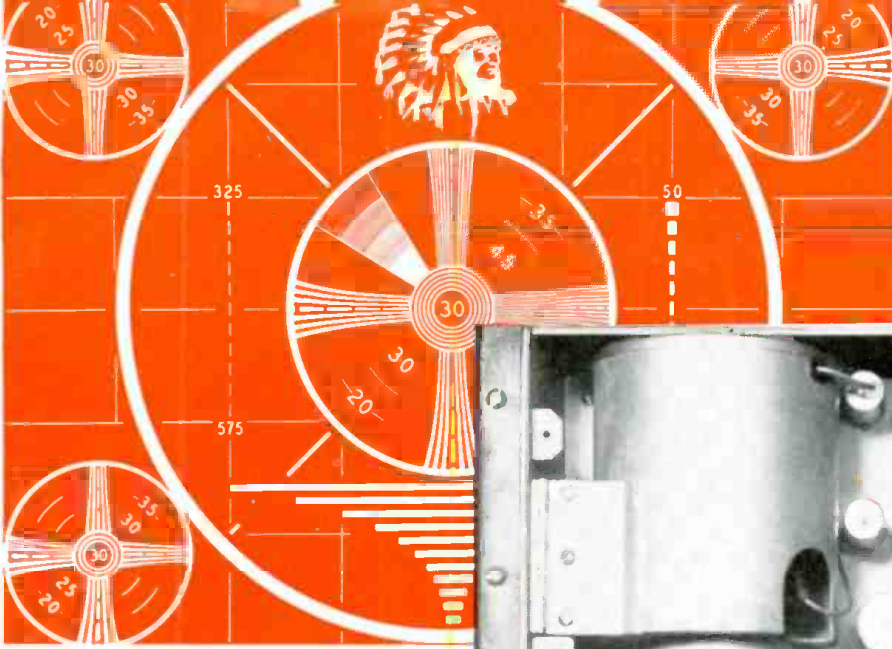

**Video  
Monoscope  
Camera  
TK-1A**

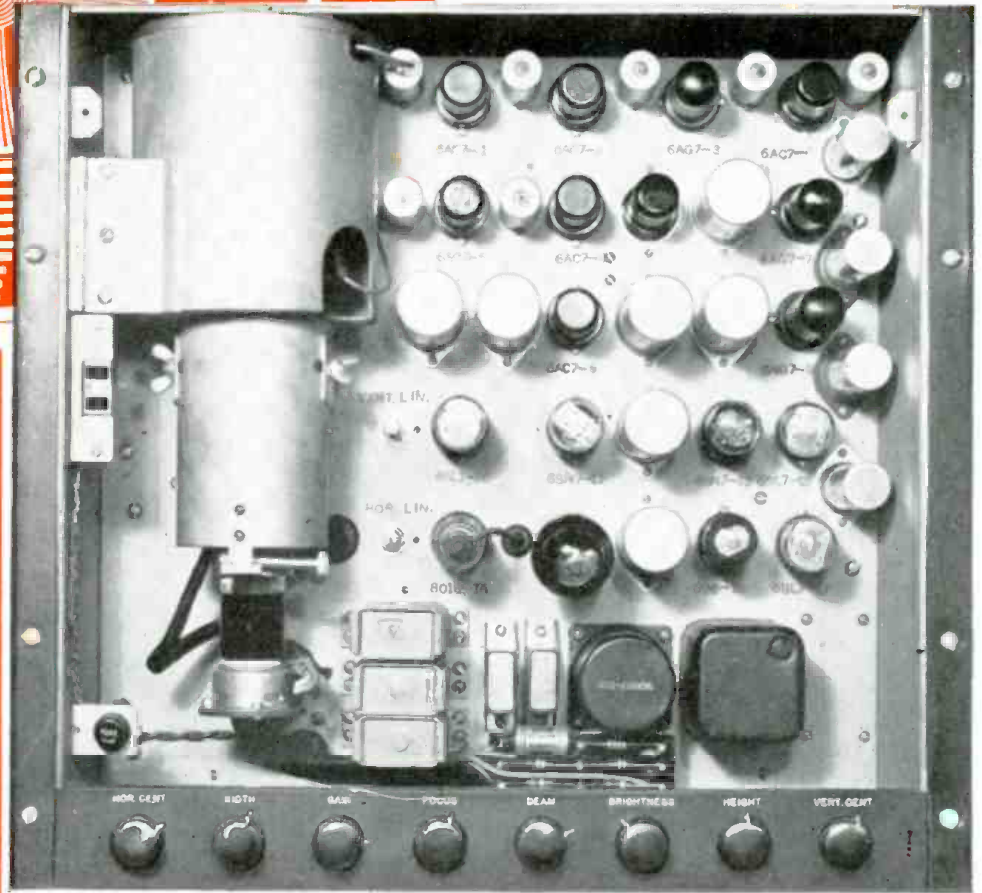

# ... "patternmaker" for the industry

The test pattern produced by RCA Monoscope Cameras is the standard by which picture quality has been judged since the beginning of electronic television . . . in TV stations . . . in laboratories . . . in TV receiver production.

These are the standard test-pattern cameras used by many TV receiver manufacturers. These are the standard "picture micrometers" used by TV stations to make precision measurements of video transmissions.

Deliberately designed to excel in all things, RCA Monoscope Cameras have earned the extraordinary re-

spect of television men. Evenly lighted patterns as steady as Gibraltar. Resolution as fixed as the cut of a diamond. Operation as reliable as a ship's chronometer.

Type TK-1A pictured here is RCA's newest Monoscope Camera—built to the highest standards known. It can be delivered to you with the familiar monoscope pattern (shown above)—or with a pattern of your own choice.

Ask your RCA Television Equipment Sales Engineer for prices. Mail the coupon for data.



**TELEVISION BROADCAST EQUIPMENT**  
**RADIO CORPORATION of AMERICA**  
**ENGINEERING PRODUCTS DEPARTMENT, CAMDEN, N. J.**

In Canada: RCA VICTOR Company Limited, Montreal

Radio Corporation of America  
Television Broadcast Equipment Section  
Dept. Q-23, Camden, N. J.

Send me your technical bulletin on the RCA Type TK-1A Monoscope Camera.

Name \_\_\_\_\_

Company or station \_\_\_\_\_

Address \_\_\_\_\_

City \_\_\_\_\_ State \_\_\_\_\_

# Engineering a

## *Design Considerations of Antennas for Veryhigh and Ultrahigh Bands, Involving the Vertical Pattern, Field-Strength Coverage, Holes in Coverage Areas and Ultimate Design.*

Left: Raising of a 12-bay super-gain antenna.

THE TREND TO HIGHER and higher effective radiated power has followed two engineering paths; higher power transmitters, and super-gain antennas, where a super-gain antenna may be defined as one in which the power gain relative to a dipole is ten or more. In a comparison of the two methods it has been found that the super-gain antenna has negligible maintenance, lower operating costs, and a lower initial cost.

With a higher gain antenna, more bays are needed with a consequently greater deicing power being necessary. This results in slightly higher operating cost, but not to compare with a

high power amplifier. Although a larger antenna puts more load on the tower structure, this is partially offset by the fact that the length of the antenna raises its center of radiation. Thus, on the basis of a fixed radiation height, a shorter tower is required for the long antenna, which may offset any added cost for a heavier tower. In practice, the shorter tower is usually the lower section of a standard tower.

### *The Price of Super Gain*

Usually the *rhf* or *uhf* antenna is an omnidirectional antenna; one which

radiates equally in all horizontal directions. Just where does the gain come from? Suppose we placed our fingers on an imaginary axis of a perfectly-round balloon and squeezed; the balloon would bulge out around the equator, and the more volume we squeeze down, the greater the bulge. The balloon represents the radiation from the antenna. With a constant power flowing into the antenna and with the radiation suppressed in certain directions, the power intensity or outflow must increase in other directions. Thus, when we speak of super gain, we achieve this in a horizontal plane and at the expense

Figure 1

Plot of number of bays versus beamwidth for a super-gain antenna.

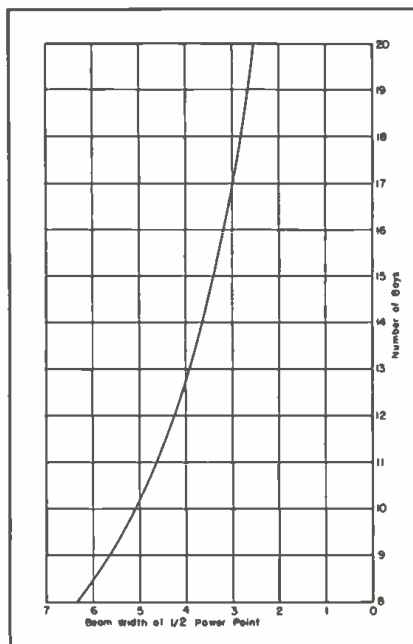
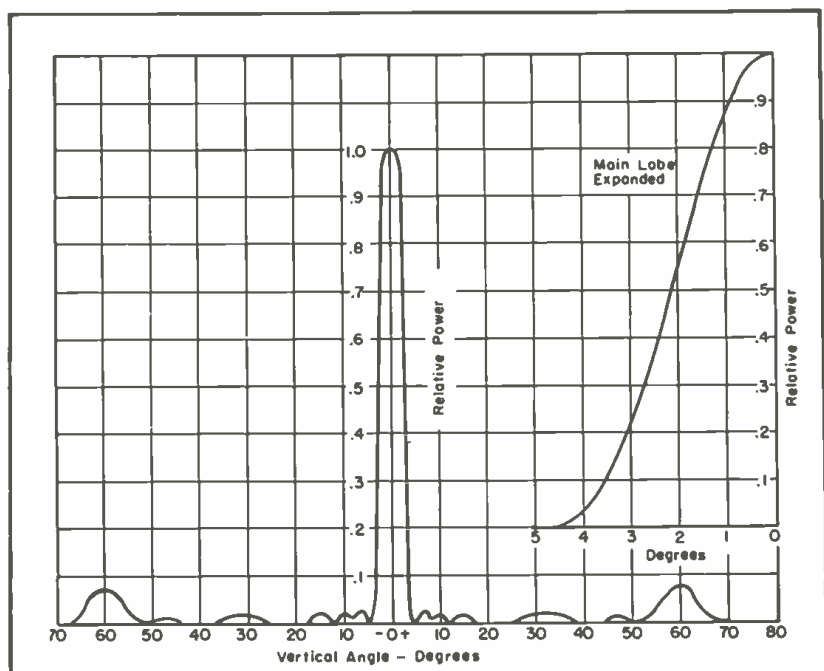

Figure 2

Calculated vertical pattern for a 12-bay antenna, plot applying to transmission on channel 9.



# Super-Gain TV Antenna

by M. E. HIEHLE,\* *Hughes Aircraft Company*

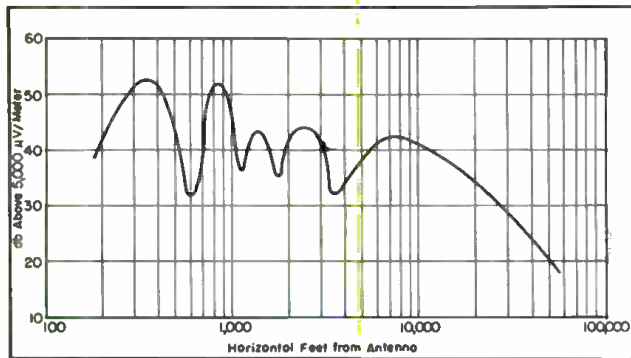

Figure 3

Field-intensity plot at short range of 6-bay antenna. Frequency, 195 mc; transmitter antenna, 500'; receiving antenna, 30' and power 24 kw erp.

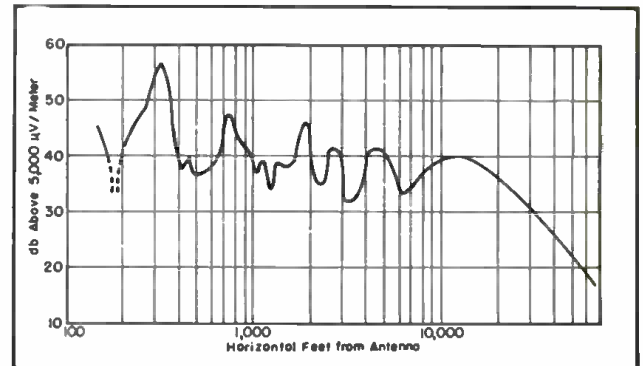

Figure 4

Field intensity of 12-bay antenna, operating at 195 mc, with a height of 500' and a power of 45 kw erp.

of radiation up and down. Fundamentally, the super-gain antenna must therefore have a very narrow vertical pattern. From this fact, we can determine some of the limits of design.

From a broadcaster's standpoint, subject to FCC limits, the maximum gain possible is desired since this gives a maximum *erp*. However, there is a practical limit, since the vertical pattern becomes so narrow as to endanger reception due to tower and antenna sway. A second possible limit to set maximum gain is the *hole* in reception area close to the antenna. This is the territory where the narrow beam shoots out over the heads of the receivers. To consider these two factors, it is necessary to have a good knowledge of the vertical pattern of the super-gain antenna and of the propagation affecting the radiation.

## Vertical Pattern

High gain is currently achieved by vertically stacking similar bays and feeding them in phase. While other types of stacking may be employed, the vertical stacking method gives the highest center of radiation, consequently minimizing tower height. For an in-phase current multibay antenna, the vertical pattern is given by

$$E = \text{Sin} \frac{(n \pi d/\lambda \sin \theta)}{n \sin (\pi d/\lambda \sin \theta)} E\theta \quad (1)$$

where  $E$  is the field strength,  $d$  the spacing between centers of bays,  $n$  the of tower and antenna; and (4) inherent

for 30-pound wind loading (85 mph number of bays and  $\theta$  the vertical angel of radiation.  $E\theta$  is the radiation function of a single bay and approximates a cosine function for antennas of the circular loop, superturnstile, square loop and cloverleaf types. Figure 1 shows the vertical beam width at half power as a function of number of bays with bay spacings of  $\lambda$  for this type of antenna. For a given antenna aperture (length) and using individual bays having a vertical pattern similar to a cosine curve, the maximum gain achievable occurs with the bay spacing a little more than half wave. However, the gain decreases very little with bay spacings up to one wavelength. In view of the much-simplified antenna structure, the one wavelength spacing is customarily used. Thus, for a 12-bay antenna, the beam width would be  $4.2^\circ$  to the half power points.

Besides the main lobe, there are additional minor lobes, and usually deep nulls between minor lobes. Figure 2 illustrates the vertical power pattern of a 12-bay superturnstile antenna as calculated from equation (1) and shows the minor lobes and nulls clearly; these minor lobes are necessary to produce the close-in reception field.

There are several factors that combine to produce beam tilt, thus limiting the antenna vertical beam width. These are (1) tower sway; (2) antenna flexing; (3) vertical alignment

\* Formerly with General Electric, engaged in the engineering of the WHAS super-gain antenna.

electrical cocking of antenna beam. Of these four factors, only the first two are variant; the later two comprise a fixed beam cocking.

An investigation of these factors has revealed that high winds have negligible bending effects on guyed towers or solid buildings. However, for a well constructed heavy duty 500-foot self-supporting tower, a 30-pound wind loading (corresponding to 115-mph indicated velocity) may deflect the tower approximately 14 inches or some  $0.4^\circ$  if a major part of bending can be considered over the upper section of the tower. For this same wind velocity, a typical 75-foot steel pole antenna will deflect about 33 inches. Weighing this deflection, since the whole antenna does not bend, has been found to result in an average tilt of  $2.15^\circ$  for the antenna.

The plumb of the antenna with respect to the tower, plus the plumb of the tower, can be held to a total of  $0.5^\circ$ , provided the antenna is adjusted by means of line-up bolts and a transit. In case the tower is out of line, this can be corrected by overcompensating the antenna line up. Due to a possible settling of tower foundations, a careful recheck of plumb must be made about a year after installation. Manufacturing tolerances of the antenna itself add a fourth error in beam tilt. By careful design this can be held to  $0.25^\circ$ .

Summarizing, a typical *vhf* TV or FM antenna set on a 500-foot self-supporting heavy duty tower operating in an 115-mph indicated wind velocity will have a possible beam tilt of  $3.3^\circ$ , of which  $2.55^\circ$  are oscillatory.

While considerations have been made

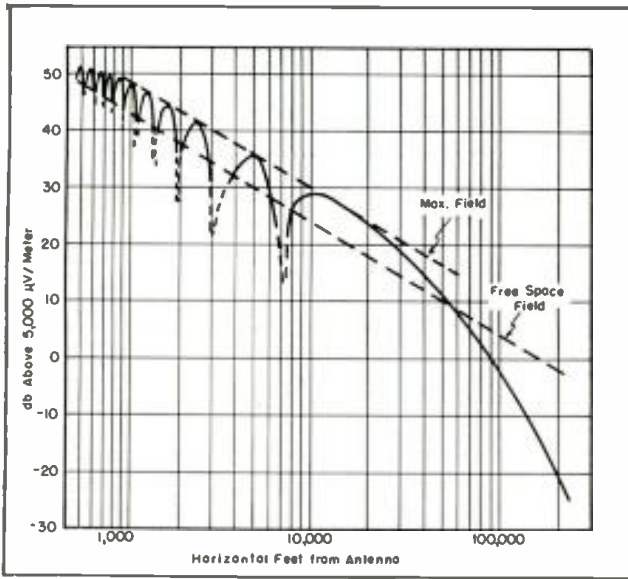

Figure 5

Ground interference pattern. Frequency, 195 mc; transmitting antenna height, 500'; receiving antenna, 30', and power, 1 kw.

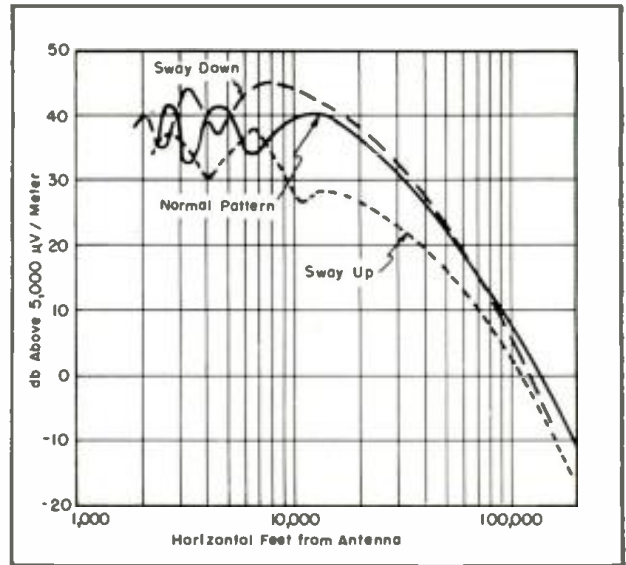

Figure 6

Variation of 12-bay field intensity due to 2° sway. Frequency, 195 mc; transmitting antenna, 500'; receiving antenna, 30', and power 45 kw erp.

actual wind velocity), it is seldom that this condition is encountered. Although the structural designer must keep this higher figure in mind, a more practical figure would be 50 mph actual velocity for serviceable operation, corresponding to 10 pounds per square foot loading. On this basis the deflection due to tower and antenna sway reduces to 0.85°.

**Field-Strength Coverage**

By simple geometry, the angle of depression for any given range and antenna height may be shown to be

$$\tan \theta = .0001895 \left[ \frac{h}{s} + \frac{s}{2} \right] \quad (2)$$

Where:  $\theta$  = depression angle  
 $h$  = antenna height in feet  
 $s$  = range in miles

In this derivation the earth's radius has been taken at 5,280 miles to allow for propagation diffraction effects. Applying equation (2) to a known antenna will provide the information as to change of field intensity due to tilted beam. If the propagation attenuation characteristics are known, as for example the ground wave signal ranges, as given in the *FCC Standards of Good Engineering Practice*, the absolute field intensity can be calculated. In Figures 3 and 4 are two antenna field-intensity curves, the first for a six-bay antenna with a 7.5° beam width and the second for a 12-bay with 4.2° beam width. The data were computed on the basis of measured antenna patterns and the FCC propagation curves. A transmitter power of 5 kw, 70% efficient transmission lines, 500-foot transmitting antenna height and a 30-foot receiving antenna height were assumed. This corresponds to 24-kw erp for the six-bay and 45 kw erp for the 12-bay antenna; operation at 195 mc. These

(Continued on page 27)

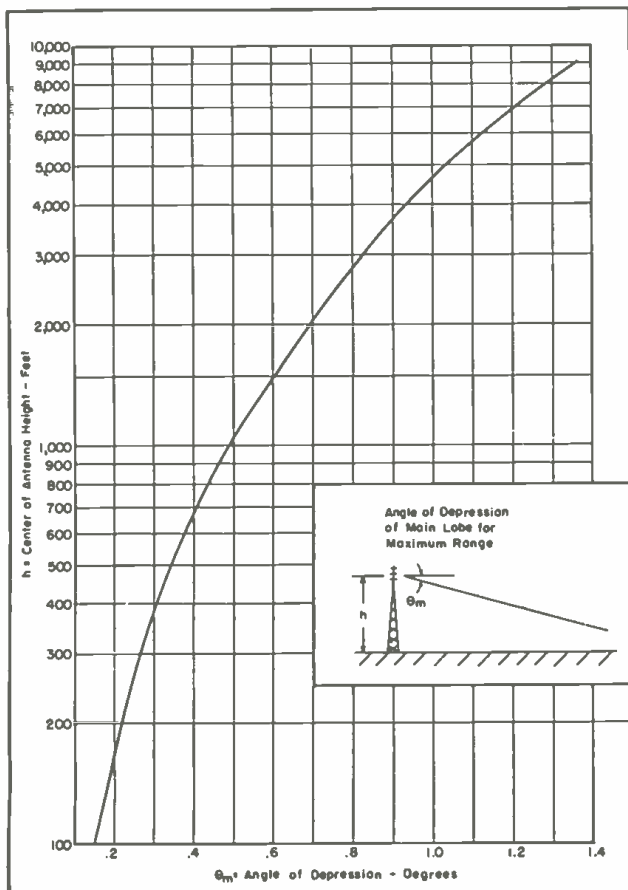
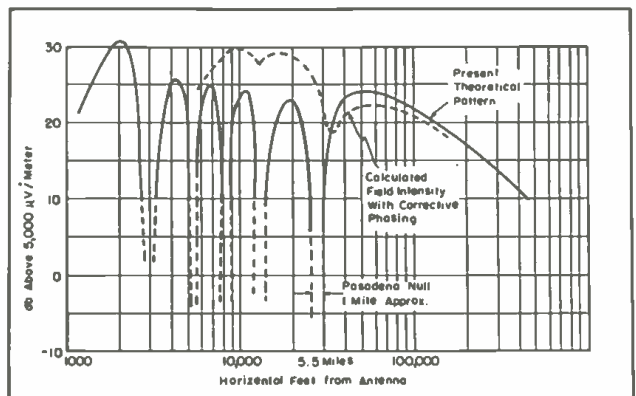

Figure 7 (Left)  
 Main lobe depression for maximum range.

Figure 8 (Below)  
 Field-intensity pattern for a 6-bay antenna. Frequency, 177 mc; transmitting antenna height, 5000'; receiving antenna, 30', and power 25 kw erp. Curve made at KECA-TV.





**DON'T LET HIM "PITCH" YOU  
BLACK  
IS  
WHITE...**

**INSIST ON**

**Sheldon "Telegenic" Picture Tubes**

where **BLACK IS BLACK-**

**WHITE IS WHITE-** *and between*

**ALL THE NATURAL**

**INTERMEDIATE SHADING!**

This FULL RANGE of picture tones seen only on Sheldon "Telegenic" Picture Tubes, makes possible MAXIMUM CONTRAST with CLARITY . . . with NO EYE STRAIN and NO GLARE . . . whether on a Velour Black or clear face screen . . . whether viewed in daylight or under artificial light.

Superior picture quality is the reason why Sheldon Picture Tube production has been stepped up to 5,000 daily! This production increase is made possible by another recent installation of the most modern in-line exhaust unit in the industry.

**SHELDON ELECTRIC CO.**

A Division of ALLIED ELECTRIC PRODUCTS INC.  
68-98 Coit Street, Irvington 11, N. J.

Branch Offices & Warehouses:  
CHICAGO 7, ILL., 426 S. Clinton St. • LOS ANGELES 26, CAL., 1755 Glendale Blvd



Manufacturers of  
SHELDON TELEVISION PICTURE TUBES  
CATHODE RAY TUBES • FLUORESCENT  
LAMP STARTERS AND LAMP HOLDERS  
SHELDON REFLECTOR & INFRA-RED  
LAMPS • PHOTOFLOOD & PHOTOSPOT  
LAMPS • TAPMASTER EXTENSION CORD  
SETS & CUBE TAPS • SPRING-ACTION  
PLUGS • RECTIFIER BULBS

WRITE FOR VISUAL PROOF  
OF SHELDON'S SUPERIOR PICTURE QUALITY!

**MAIL COUPON TODAY**

Sheldon Electric Co., 68 Coit St., Irvington 11, N. J. B

Send  Proof of Picture Quality  
 "Characteristics and Dimensions" Wall Chart  
 "Television Mis-Information"  
 "Ion Burns—How to Prevent Them" Brochure  
*(They're free — but PLEASE PRINT)*

Name \_\_\_\_\_ Title \_\_\_\_\_  
 Company \_\_\_\_\_  
 Street \_\_\_\_\_  
 City \_\_\_\_\_ Zone \_\_\_\_\_ State \_\_\_\_\_

VISIT BOOTH NO. 201, PARTS DISTRIBUTOR SHOW, STEVENS HOTEL, CHICAGO, MAY 21-23.

© 1951—ALLIED ELECTRIC PRODUCTS INC.

...*“It was easy to conduct  
a person-to-person canvass  
at all company plants  
and offices”*

**ROY A. HUNT**  
President, Aluminum Company  
of America

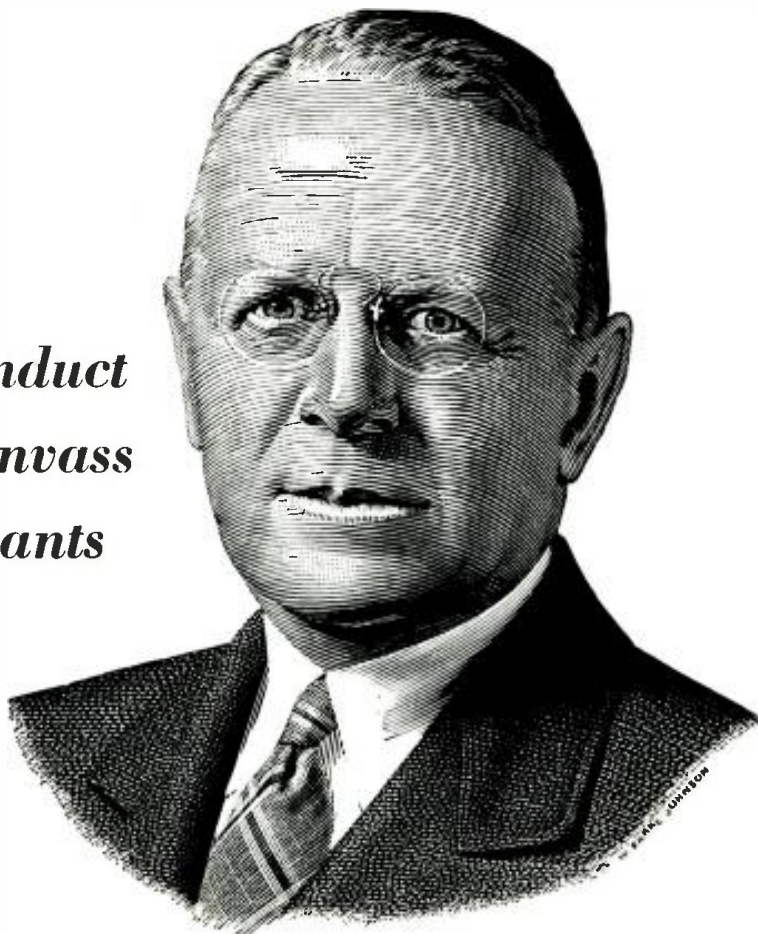

*“Our employees like the Payroll Savings Plan for U. S. Savings Bonds. It was easy, therefore, to conduct a person-to-person canvass at all company plants and offices.*

*“I believe every company which promotes the systematic investment in U. S. Savings Bonds in this way provides a highly desirable service for its employees and at the same time gives practical support to an important national effort.”*

Yes, it is easy to conduct a person-to-person canvass of your offices and plants to ascertain who wants to help America and build for his or her security by the systematic purchase of U. S. Defense Bonds through the Payroll Savings Plan. Have you conducted a person-to-person canvass in your plant?

If you haven't, here are the three easy steps:

- Phone, wire or write to Savings Bond Division, U. S. Treasury Department, Suite 700, Washington Building, Washington, D. C.
- Your State Director, U. S. Treasury Department, will contact you or the executive you designate to conduct the canvass and tell you exactly how to proceed. He will furnish posters, pay envelope stuffers, application blanks and other aids.
- All you have to do is to see that every employee in

your company is handed a Payroll Savings Application and given an opportunity to make his or her own decision. No pressure is needed.

Simple as the plan is, it works — to the benefit of employees, the company and America. In the last six months approximately 4,000 more companies have installed the Payroll Savings Plan for their employees. Approximately 600,000 working men and women have joined the millions of smart savers already on the Payroll Savings Plan. In plant after plant, employee participation has jumped to 70%, 80% — even 90% because, as Mr. Hunt so aptly puts it, “employees like the Payroll Savings Plan.”

Make it easy for *your* employees to help themselves, their Country and their company by the systematic purchase of U. S. Savings Bonds — Defense Bonds now, because they are an important factor in combating inflation and building a stronger America.

*The U. S. Government does not pay for this advertising. The Treasury Department thanks, for their patriotic donation, the Advertising Council and*

**TELEVISION ENGINEERING**



# Cathode-Coupled Clipper Response Speed

by PHILIP F. ORDUNG and HERBERT L. KRAUSS

Dunham Laboratory, Yale University

**Part II of System Study, Which Discloses That the Cathode-Coupled Clipper Is Capable of High-Speed Operation If Tubes With Low-Inter-electrode Capacitances and High  $G_m$  Are Used.**

DYNAMIC TESTS have been found to be particularly helpful in probing the operational characteristics of circuits; in the instance of clipper systems, such tests have served to determine how the unavoidable capacitances between tube elements, across resistors, and resulting from wiring, affect the operation of clippers, and which of them exert a predominant influence on the highest speed of operation.

The input pulse,  $e_{g1}$ , and a 20-mc timing wave that were common to all of the dynamic tests in our study, appears in Figure 3. The input pulse had an amplitude of approximately 8 volts, and a duration of approximately .05 microseconds. When this voltage was applied to a basic clipper circuit (Figure 1), it was possible to secure waveforms of output voltage,  $e_{p2}$ , and cathode voltage,  $e_k$ , shown in Figure 2.

It was found that the input pulse,  $e_{g1}$ , has sufficient amplitude and sufficiently short rise time so that the grid of tube 1 is driven through the transition interval in a time that is very short compared to the response time of the circuit. The cathode voltage rises and decays approximately as rapidly as the input pulse; therefore the plate current  $i_{p2}$  of tube 2 is cut off instantly at the beginning of the input pulse and started quickly at the end of the input pulse. However, the waveform of the output plate voltage,  $e_{p2}$ , shown in Figure 2, looks very much like the characteristic charge and discharge curves of a simple  $rc$  circuit, which consists of the plate load resistance and the aggregate capacitance from the plate to ground. This was confirmed experimentally by a measurement of the impedance from plate to ground with an  $rf$  bridge. The measured impedance was equivalent to a resistance of 1090 ohms in parallel with a capacitance of 13.2 mmfd, giving a time constant of 14.4 millimicrosec-

onds, a value approximately the same as the time constant of the  $e_{p2}$  curve in Figure 2.

Further confirmation that the rise and decay times of the  $e_{p2}$  curve of Figure 2 were due almost entirely to the time constant of the output circuit appears in Figures 4 and 5. In Figure 4 the waveforms for cathode voltage  $e_k$  and output voltage  $e_{p2}$  of Figure 2 are repeated, along with the waveforms indicated by primed symbols observed when a capacitance of 30 mmfd was added from the cathode to ground. Although the added capacitance increased slightly the rise time of the cathode voltage, it did not affect the rise time of the output voltage because the plate current,  $i_{p2}$ , was cut off at the moment that the output voltage started to rise. The cathode voltage was found to decay much more slowly than it rises, because the charging current of the cathode capacitance is supplied through tube 1, whereas the discharging current can flow only through the cathode resistor. Since the cathode resistance is considerably larger than the equivalent resistance of tube 1 (at its cathode terminal), the discharge time constant of the cathode circuit is longer than the charging time constant. With the added capacitance, used to obtain Figure 4, the time constants of the cathode circuit are long enough to have an appreciable effect. The slow decay of the cathode voltage delays the transition of current from tubes 1 and 2, thereby delaying

(Continued on page 22)

Figures 2, 3, 4 and 5  
The input, output and cathode voltages of the clipper appear in Figure 2 (top). Below (Figure 3) is a 20-mc calibration wave. The output and cathode voltages, before and after an additional capacitance of 30 mmfd was connected from cathode to ground, are shown in the next plot (Figure 4). In Figure 5 appear the output and cathode voltages, before and after an additional capacitance of 30 mmfd was connected from output plate to ground.

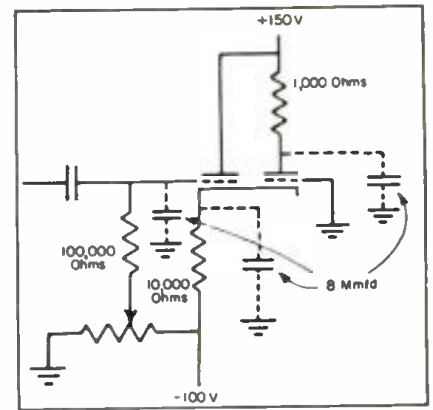
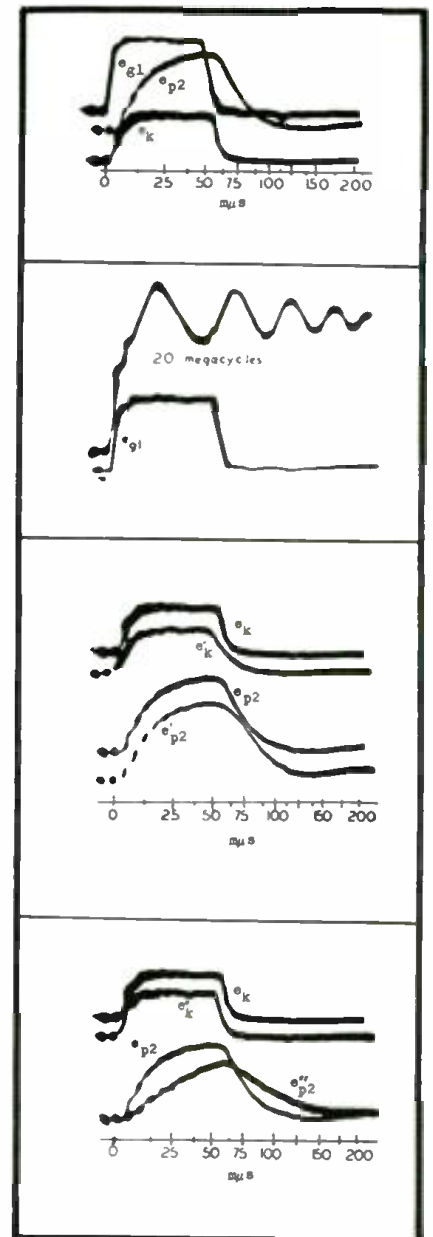

Figure 1  
Basic circuit of the cathode-coupled clipper. The 8-mmfd capacitors were used to compensate for the 8-mmfd 'scope input capacitance.



# Group Subscription Plan

You Save Half of the Subscription Price if  
Four or More Orders, Including Your Own,  
Are Properly Entered on This Form

## TELEVISION ENGINEERING

52 Vanderbilt Avenue, New York 17, N. Y.

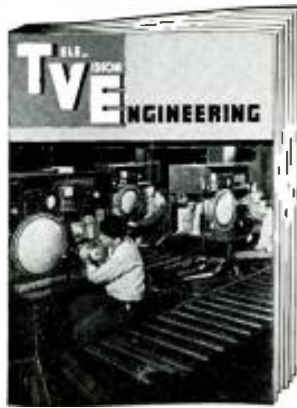

Two years (24 issues) at the rate of \$3.00 each. This rate applies only on 4 or more subscriptions when occupations are given.) Regular cost is \$3.00 for one year.

### USE COUPON BELOW

-----  
 Name .....  
 Address .....  
 City..... Zone..... State.....  
 Occupation..... Title.....  
 Department in which employed  
 Operation                       Production                       Research  
 Employed by.....  
 Nature of Business.....  
 (State if TV Manufacturer, TV Broadcast Station, etc.)

-----  
 Name .....  
 Address .....  
 City..... Zone..... State.....  
 Occupation..... Title.....  
 Department in which employed  
 Operation                       Production                       Research  
 Employed by.....  
 Nature of Business.....  
 (State if TV Manufacturer, TV Broadcast Station, etc.)

-----  
 Name .....  
 Address .....  
 City..... Zone..... State.....  
 Occupation..... Title.....  
 Department in which employed  
 Operation                       Production                       Research  
 Employed by.....  
 Nature of Business.....  
 (State if TV Manufacturer, TV Broadcast Station, etc.)

-----  
 Name .....  
 Address .....  
 City..... Zone..... State.....  
 Occupation..... Title.....  
 Department in which employed  
 Operation                       Production                       Research  
 Employed by.....  
 Nature of Business.....  
 (State if TV Manufacturer, TV Broadcast Station, etc.)

Business or professional classifications are required to complete our records. Each subscriber should write one of the following classifications in space indicated. Use separate sheet of paper for additional names.

CHIEF ENGINEER                      ENGINEER                      EXECUTIVE  
 PURCHASING AGENT                      DEPARTMENT MANAGER

State your classification if not listed.

This Group Sent in by—  
 Name .....  
 Address .....

## Cathode Clipper

(Continued from page 21)

slightly the trailing edge of the  $e_{p2}$  pulse and increasing its time constant. If still more capacitance had been added from the cathode to ground, the transition of current to tube 2 would have been delayed for a considerable period after the trailing edge of the input pulse, but the rate of change of output voltage would have remained about the same as for the  $e'_{p2}$  curve in Figure 4. In effect, it was found the action of the additional cathode capacitance was to stretch the pulse.

In Figure 5, the output and cathode voltage waveforms of Figure 2 are compared to those designated by primed symbols obtained with 30 mmfd of additional capacitance between the output plate and ground. It will be noted that the additional output capacitance had no observable effect on the cathode voltage waveform, but that the time constant of the output plate circuit was increased so much that the output voltage did not have time to build up to full value.

These tests disclosed that with the essentially rectangular input pulse that was used, the output voltage waveform is determined primarily by the time constant of the output circuit. Therefore the application of regenerative feedback, which has the effect of narrowing the transition interval, should have no appreciable effect on the speed of response at the output terminal.

[To Be Concluded in June]

### Studio Camera Channel

A STUDIO CAMERA CHANNEL, pre-wired and fitted with plug and cable connection, has been developed.

The channel features a lightweight camera mountable on any standard tripod or dolly. Has an image-orthicon yoke assembly mounted on ball bearing slides with plug-in connections. Damage to the tube in the event of sweep failure is prevented by a sweep protection circuit. A sweep expansion switch is provided for over-sweeping during rehearsal. Camera has a four lens turret.

Other features of the channel include dual waveform presentation and 12½-inch picture monitor.—Type PE-8-B; G.E., Syracuse, N. Y.



G.E. camera channel.



## Industry Literature

*The Magnesium Association*, 122 East 42nd St., New York 17, N. Y., has published a booklet on the uses of magnesium. Included is a discussion of the advantages of this material over other structural metals.

*Seletron Division of Radio Receptor Co., Inc.*, 251 West 19th St., New York 11, N. Y., has released a 16-page catalog on selenium rectifiers. Included are dimensions and ratings for miniature selenium rectifiers and power stacks, and background material describing many uses of these rectifiers.

*The Television Transmitter Division, Allen B. DuMont Laboratories, Inc.*, 1000 Main Ave., Clifton, N. J., has issued several equipment bulletins describing a universal color scanner, master control switch unit and master control mixer amplifier, universal console, linearity bar generator, and other TV transmitting equipment and accessories.

*Technical Appliance Corp.*, Sherburne, N. Y., has made available an engineering bulletin, No. 65, covering the application of twin-driven yagi antennas in overcoming the problem of co-channel interference. Includes gain and directivity information.

*Wirt Co.*, Box 641, 5221-27 Greene St., Philadelphia 41, Pa., has released a bulletin, No. 176, describing ceramic-core wirewound resistors with organic cement coating, vitreous enamel or refractory coating. Detailed are core dimensions with maximum wattages and resistances.

*Severance Tool Industries, Inc.*, Saginaw, Mich., has published a 12-page catalog covering mills, cutters, reamers and countersinks. Featured are a graphic index and a telegraphic code chart.

*The Cathode-Ray Tube Division of Allen B. DuMont Laboratories, Inc.*, 750 Bloomfield Avenue, Clifton, N. J., has released a 12-page picture-tube catalog describing the 30-inch type 30BP4, electrostatic-focus types 17FP4 and 20GP4, and other models. Publication also provides ion-trap-adjustment directions and basing details for both electrostatic-focus and magnetic-focus types.

*Miniature Precision Bearings, Inc.*, Keene, N. H., have prepared a 12-page catalog with specifications on more than 70 different types and sizes of miniature ball bearings. Includes details on typical applications of these bearings and photographs and diagrams of current installations.

*Helipot Corp.*, 912 Meridian St., S. Pasadena, Calif., has compiled a reference technical-data chart on single-turn and multi-turn potentiometers. Detailed are electrical and mechanical characteristics, physical dimensions with accompanying sketches, power ratings, etc., units in single-turn and multi-turn designs.

*Pyramid Electric Co.*, 1445 Hudson Boulevard, N. Bergen, N. J., have released a 52-page catalog describing hermetically-sealed miniature tubulars, hermetically-sealed oil-paper capacitors in metal tubes and rectangular containers, hermetically-sealed paper capacitors in bathtub containers, dry metal-tube electrolytics, etc.

TeleVision Engineering, May, 1951



**FIXED RESISTORS**  
( $\frac{1}{2}$ -, 1- and 2-watts)



**VARIABLE RESISTORS**



**IRON CORES**



**CERAMAG® (FERRITE) CORES**



**LINE AND SLIDE SWITCHES**



**CHOKE FORMS**



**GA CAPACITORS**

# WRITE FOR NEW CATALOG



Your request (on company stationery) will bring you this new 42-page catalog containing latest data on the complete line of standard Stackpole electronic components plus helpful engineering data. Ask for Catalog RC-8.

# STACKPOLE

Electronic Components Division

**STACKPOLE CARBON COMPANY**

St. Marys, Pa.

## Ferrite Core Parts

HIGH-PERMEABILITY ferrite core parts using non-critical materials have been announced.

Transformer cores, deflection yoke cores, antenna cores, and permeability tuning cores using this ferrite material (Ferroxcube 3 and 3C) which is nickel-free, are available.—*Ferroxcube Corp. of America, 50 E. 41st St., N. Y. 17, N. Y. (Bulletin FC-5101 contains further details.)*

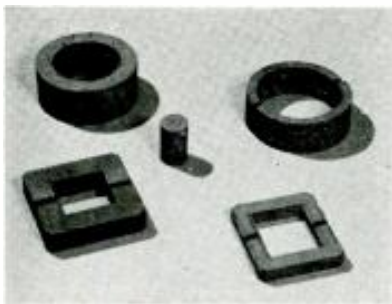

Ferroxcube forms.

## Solderless Molded Terminal Blocks

SOLDERLESS TYPE *Bepco* molded terminal blocks are now available with compression type solderless units, each capable of receiving wires from No. 16 to 6 awg. Typical combinations which may be accommodated by a single terminal are two No. 10, two No. 12 or two No. 14; one No. 12 with one No. 10, one No. 12 with one No. 14, etc. Attachment of wires to block is accomplished by tightening screws after insertion of stripped wires. Blocks are rated at 35 amperes, 600 volts, and are available in 4, 8 and 12 circuit sizes. Screw-on covers are available.—*Buchanan Electrical Products Corp., 1290 Central Ave., Hillside, N. J.*

## High Megohm Resistors

HIGH MEGOHM RESISTORS with resistance values as high as 50-million megohms have been announced. One inch resistor, 5 megohms to 10 million megohms, has a maximum voltage of 3500. Three inch resistor, with a maximum voltage of 15,000, has a 20 megohm to 50-million megohm resistance range. Voltage coefficient for most resistance values is said to be  $-.0001$  per cent per volt.—*Type H; Resistance Products Co., 714 Race St., Harrisburg, Pa.*



RPC high-megohm resistors.

## Ceramic Components

CERAMIC FORMS for slug-tuned coil-form assemblies, feed-through insulators and terminal boards are now available.

One slug-tuned coil-form assembly, using grade L-5 silicone impregnated ceramic, has a  $\frac{5}{8}$ " hex mounting base,  $1\frac{11}{16}$ " *oa* mounted height. Diameter is  $\frac{1}{2}$ ". Has adjustable ring terminals, and spring lock for slug. Mounts in single  $\frac{1}{4}$ " hole for high, medium or low frequency slug. A second slug-tuned coil form features silver-plated phosphor bronze clip terminals. Height is  $23/32$ "; maximum diameter,  $\frac{1}{2}$ ". Mounts in *D* punched hole or in  $\frac{1}{4}$ " round hole. Provided with a spring lock.

Feed-through insulator is  $\frac{7}{8}$ " *oa* length, including through terminal with a  $\frac{3}{8}$ " hex bushing threaded for  $\frac{1}{4}$ " hole mounting. Voltage breakdown 4800 volts rms at 60 cycles ac.

Terminal board, also of grade L-5 silicone impregnated ceramic, is  $35/64$ " *oa* mounted height, including terminals;  $1\frac{1}{4}$ " length,  $\frac{7}{8}$ " width, assembly of eight terminals in 2 rows, 4 per row,  $9/16$ " apart, plus two 4-40 tapped standoffs  $3/16$ " high on  $5/8$ " centers. A center ground strap is provided to which standoffs are riveted and soldered for grounding at rf frequencies.—*LS-7, LS-8, X1990, X1986; Cambridge Thermionic Corp., 442 Concord Ave., Cambridge, Mass.*

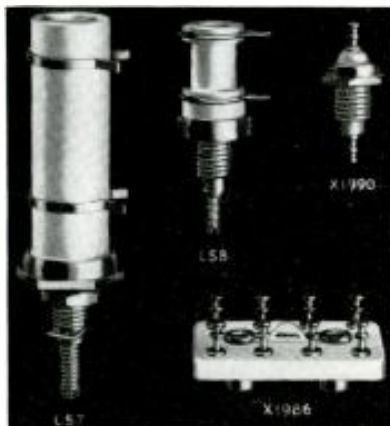

Cambridge Thermionic ceramic components.

## Wire and Spool Tension

TENSIONS, designed to handle wire sizes, 14 to 28, and spools up to 8" diameter, have been developed.

Tension can be used on winding machines, for heavy industrial coils, heavy bobbin coils, field coils and similar types, and for dereeling steel wire, copper wire and heavy textile covered wire. Can be operated either horizontally or vertically to fit the requirements of the winding, and is said to be easily adjusted by thumb nut. Light, medium and heavy springs for handling different sizes of wire are supplied with each unit.—*Model T-8; Geo. Stevens Manufacturing Co., Inc., 6022 N. Rogers Ave., Chicago 30, Ill.*



Stevens wire and spool tension.

## Metallic Paint

SILVER PAINT that is electrically conductive and is said to have a high degree of durability and heat resistance, combined with low electrical resistance, has been produced. Paint is said to be adhesive to most insulating and metallic surfaces except those which are too soft or flexible, and may be baked on with one-half hour bake periods at  $325^{\circ}$  F.—*SCT series; Micro-Circuits Co., New Buffalo, Mich.*

## Cable Jackets

A THERMOPLASTIC CABLE JACKET that is said to be able to withstand flexing at temperatures of  $-40^{\circ}$  C after a 14-day aging at  $+80^{\circ}$  C, has been announced.

Developed for use in high-frequency RG/U cables, the jacket has a plasticized copolymer of vinylchloride-acetate, and pigmented black that is said to minimize the effects of ultra-violet radiation.—*IN-11D; Federal Telephone and Radio Corp., Clifton, N. J.*

## Hollow Mills

SMALL HOLLOW MILLS, having an *od* of  $\frac{5}{8}$ " inch and under, are now available. Hollow mills are not stock items, each being designed and manufactured to meet specific customer requirements.

Machined of carbon or high-speed steels or special steel alloys, these hollow mills may be plain or adjustable, with internal or external steps, for left hand or right hand screw machine work.—*Woodruff and Stokes Co., Inc., 349 Lincoln St., Hingham, Mass.*

## WHEN YOU CHANGE YOUR ADDRESS

Be sure to notify the Subscription Department of TELEVISION ENGINEERING, 52 Vanderbilt Avenue, New York 17, N. Y., giving the old as well as the new address, and do this at least four weeks in advance. The Post Office Department does not forward magazines unless you pay additional postage, and we cannot duplicate copies mailed to the old address. We ask your cooperation.

# Instruments

## Capacitance Meter

A CAPACITANCE METER that is a direct reading, ac operated instrument, has been announced. Capacitance is read on a four-inch indicator with a logarithmic scale in ranges of .1, 1, 10 and 100 mmfd. Accuracy is said to be better than 5 per cent and reproducibility better than ½ per cent. Measurements are made at 500 kc.—*Model 351; MacLeod and Hanopol, Inc., 10 Joiner St., Charlestown 29, Mass.*



MacLeod and Hanopol capacitance meter

## Low-Range RF Capacitance Meter

A RF CAPACITANCE METER, with two ranges, 0 to 10 and 0 to 100 mmfd has been produced. Values can be switched automatically by rotating the main capacitance dial. Instrument has a self-contained 1-mc oscillator and resonance indicator.

Unit can provide measurement of tube-socket capacitances by means of socket adaptors. A rough indication of the losses in the socket dielectric is also available. A companion instrument can be used to extend the range of measurements up to 1000 mmfd.—*Type 1612-A1 and type 1612-A; General Radio Co., 275 Massachusetts Ave., Cambridge 39, Mass.*



G-R rf capacitance meter

## Automatic Capacitance Comparator

AN AUTOMATIC CAPACITANCE COMPARATOR that checks, grades and matches 10-mmfd to 1000-mfd capacitors has been developed. Employs a bridge circuit which compensates for line voltage variations. Unit is said to have an accuracy of better than 1 division of scale or 0.2 mmfd.—*Type PC-4; The Clippard Instrument Laboratory, Inc., Bank St., Cincinnati, Ohio.*

## Wide Band Sweep

A WIDE-BAND SWEEP with markers for aligning radar *if* amplifiers is now available. It displays amplitude versus frequency response on standard scopes.

Center frequencies are switchable to 30 or 60 mc.—*Rada-Sweep; Kay Electric Co., 14 Maple Ave., Pine Brook, N. J.*

Television Engineering, May, 1951

# RCA ELECTRONIC COMPONENTS



Typical RCA hermetically sealed and fungus-proofed power transformer for military use.

## For military requirements . . . built to military specifications

BECAUSE of its experience, engineering skill, and vast production facilities, RCA is singularly well equipped to manufacture in quantity, special transformers, chokes, filters and coils, rigidly designed to military specifications.

As one of the major suppliers of specialized electronic and television components, RCA is geared to handle your individual requirements without delay.

RCA Application Engineers are at your service—and will be pleased to confer with you on your specific military component designs. For further information, write or phone RCA, Commercial Engineering, Section 58ES, Harrison, N. J., or your nearest RCA field office.

FIELD OFFICES: (EAST) Harrison 6-8000, 415 S. 5th St., Harrison, N. J. (MIDWEST) Whitehall 4-2900, 589 E. Illinois St., Chicago, Ill. (WEST) Trinitry 5641, 420 S. San Pedro St., Los Angeles, California.



**RADIO CORPORATION of AMERICA**  
ELECTRONIC COMPONENTS  
HARRISON, N. J.

# New BIRTCHER TUBE CLAMP FOR MINIATURE TUBES



**POSITIVE PROTECTION  
AGAINST LATERAL AND  
VERTICAL SHOCK!**

The *New* Birtcher Type 2 Tube Clamp holds miniature tubes in their sockets under the most demanding conditions of vibration, impact and climate. Made of stainless steel and weighing less than 1/2 ounce, this New clamp for miniature tubes is easy to apply, sure in effect. The base is keyed to the chassis by a single machine screw or rivet . . . saving time in assembly and preventing rotation. There are no separate parts to drop or lose during assembly or

during use. Birtcher Tube Clamp Type 2 is all one piece and requires no welding, brazing or soldering at any point.

If you use miniature tubes, protect them against lateral and vertical shock with the Birtcher Tube Clamp (Type 2). Write for sample and literature!

*Builder of millions of stainless steel locking  
Type Tube Clamps for hundreds of electronic manufacturers.*

**The BIRTCHER Corporation**

5087 HUNTINGTON DRIVE • LOS ANGELES 32

# THIS IS IT! THE RELAY WITH Interchangeable Coil FOR A WIDE RANGE OF RADIO APPLICATIONS

**GUARDIAN Series 200**

**Interchangeable**

**COIL and  
CONTACT**

**Switch Assembly**



Two basic parts—a coil assembly and a contact switch assembly—comprise this simple, yet versatile relay. The coil assembly consists of the coil and field piece. The contact assembly consists of switch blades, armature, return spring and mounting bracket. The new Guardian Midget Contact Assembly which is interchangeable with the Standard Series 200 coil assembly, is also available in either single pole, double throw; or double pole, double throw.

## CONTACT SWITCH ASSEMBLIES

Cat. No.	Type	Combination	
		Single Pole	Double Throw
200-1	Standard	Double Pole	Double Throw
200-2	Standard	Double Pole	Double Throw
200-3	Contact Switch		
	Parts Kit		
200-4	Standard	Double Pole	Double Throw
200-M1	Midget	Single Pole	Double Throw
200-M2	Midget	Double Pole	Double Throw
200-M3	Midget Contact Switch		
	Parts Kit		

## 13 COIL ASSEMBLIES

A.C. COILS*		D.C. COILS	
Cat. No.	Volts	Cat. No.	Volts
200-6A	6 A.C.	200-6D	6 D.C.
200-12A	12 A.C.	200-12D	12 D.C.
200-24A	24 A.C.	200-24D	24 D.C.
200-115A	115 A.C.	200-32D	32 D.C.
		200-110D	110 D.C.
		200-5000D	

\* All A.C. coils available in 25 and 60 cycles

**GUARDIAN ELECTRIC**  
1615-F W. WALNUT STREET CHICAGO 12, ILLINOIS

A COMPLETE LINE OF RELAYS SERVING AMERICAN INDUSTRY

### Personals

W. T. FREELAND is setting up a new power tube plant in New Orleans. . . . Charlie Harris, chief engineer and vice president of Tropical Radio, is now supervising TRT's vast system which stretches from Hingham, Mass., to south of the Canal Zone. He has engineered the modernization of the company's stations, which now use frequency shift and printer service, throughout. . . . J. M. Jeffords has left his position as vocational instructor of radio in the public schools of Jamaica, N. Y., and is now connected with G. E. at Syracuse, N. Y., as test equipment design engineer. . . . C. W. Phillips has written from San Jose, Costa Rica, stating that he is still at his post as superintendent of Cia. Radiografica Internacional de Costa Rica. . . . Ken Richardson has a lab and manufacturing business in Lynbrook, L. I. . . . I. Strobino, who has been ill for some time, reports progress and hopes to go back to work soon. Good news. . . . Commander H. D. Kaulback is on duty at Headquarters, 1st Naval District, Boston, as the District Reserve Electronics Program Officer. . . . Tom Brown has been transferred to Austin, Texas, where he is zone manager for the communications division of Motorola, Inc., for Western Texas and New Mexico. Sending his

### VWOA News

regards to the old gang in TRT and UFC, he says that he would like to get aboard the old Talamanca again, soon. . . . G. P. Shandy is with RMCA, Cleveland. . . . John A. Balch, now living the life of a retired gentleman in Virginia Beach, Va., is the proud parent of three children, all of whom are in the Navy. Altho oldtimer Balch is 74 years, he has recently been on a trip to the Argentine and to Europe. Describing the trips, he says it was quite a change from his life in Hawaii, where he spent 36 years. . . . Captain George F. Shecklen, USNR, executive vice president of Radiomarine, who received the Marconi Memorial Medal of Achievement during the recent VWOA dinner-cruise, has had quite a colorful career in the airline business. In '12 he graduated from the Philadelphia School of Wireless Telegraphy, and found employment with the Marconi Wireless Telegraph Company as an operator. In '17, he enlisted in the U. S. Naval Reserve and served as a chief radio electrician until '19. Immediately thereafter, he rejoined the Marconi company as a supervisor-operator, transferring to RCA

when RCA took over the Marconi stations. During the next 5 years, he advanced through the ranks to become a sales manager at Los Angeles, Calif. Later he was transferred to China to improve the radiotelegraph service between that country and the United States. While in the Orient, he set up the now-famous Radio Central at Shanghai and was appointed honorary advisor to the Chinese Ministry of Communications and the National Committee for Reconstruction. He was made China Representative for RCA in '28 and was elected a vice president of RCA Communications, Inc., in '35. In '39, he returned to this country and was named commercial manager of RCA Communications, a post he held until December 7, '41. At the outbreak of World War II, Shecklen was recalled to active duty, with the rank of Lieutenant Commander. He served as Communications Officer, U. S. Censorship Bureau and as Communications Officer, third Naval District, at which time he was advanced to the grade of Commander. He was returned to inactive duty status in October '45, at which time he became associated with Radiomarine as vice president and general manager. In Dec., '45 he was appointed executive vice president and elected a director of Radiomarine.

## Super-Gain Antennas

(Continued from page 18)

curves do not include the nulls caused by the tower-height interference pattern since the nulls are encountered regardless of type of antenna. For reference, Figure 5 illustrates the nature of the interference pattern which additionally modulates the antenna field strength curve.

In Figure 6 appears the variation of field strength due to antenna bending for conditions of a 12-bay antenna with 4.2° beam width and 2° bending. At a range of 200,000 feet, the field strengths were found to drop 5 db, when the antenna beam swung up and 2.8 db when the antenna pointed down. The asymmetry of results was found to be due to the antenna beam in normal position being parallel to the earth's surface, whereas it should be tilted downward for maximum intensity at far range. By using proper tilt angle, the intensity for either up or down sway would be the same or -3 db.

The actual angle of depression required for the beam to give full signal strength at the maximum range can be expressed as

$$\theta = .0154 \sqrt{h} \quad (3)$$

where  $\theta$  (in degrees) is the angle of depression of main lobe and  $h$  the transmitter antenna height in feet. In Figure 7 appears the plot for equation (3): for a 500-foot transmitting antenna height it will be noted that there is a 0.35° depression for maximum effectiveness of pattern.

As previously pointed out, the 2° bending represents the most severe conditions. For the more normal case of 50 mph with a 1.28° beam tilt, the field-strength decreases for the same antenna are 3.2-db beam tilted up and 2.2-db beam tilted down. If the antenna were pre-tilted the decreases would be on the order of 2.5 db for either sway. These variations of signal strength are very low and would cause no reception problem.

### Holes in Coverage Area

In Figures 3 and 4 can be seen a scalloping of the field intensity. This is caused by the vertical lobular pattern of the antenna and thus we find that the minor lobes have a very important function in providing the close-in coverage. For the 12-bay antenna (Figure 4) the first null was found to occur at 6,300 feet or little over a mile, all others being closer in. For a theoretical design antenna with all bays in phase and equal currents these nulls drop to zero. Practically, it is almost impossible to achieve this condition and



First in the field for 41 successive years, C-D transmitter capacitors have to be good to get where they are today.

Available through all Authorized C-D Distributors. Write for complete technical data, Cornell-Dubilier Electric Corp., Dept. TV-5, South Plainfield, N. J.



CONSISTENTLY DEPENDABLE  
**CORNELL-DUBILIER**  
CAPACITORS

Plants in South Plainfield, N. J.; New Bedford, Worcester, and Cambridge, Mass.; Providence, R. I.; Indianapolis, Ind.; Fuquay Springs, N. C.; and subsidiary, The Radiant Corp., Cleveland, Ohio

there is a null minimum instead of a null zero. Because of propagation attenuation, the energy close into the antenna is of fairly high level and the null minimums still provide sufficient field level for satisfactory operation. Both the 6-bay and 12-bay antennas of Figure 3 and 4 show this condition. In neither case does the level drop below 200,000 microvolts per meter. Nor will antenna sway increase the null depth: it will merely change the ranges as can be seen from Figure 6.

The salvation from deep nulls occurs because of manufacturing tolerances of

the antenna and because the nulls appear close to the antenna. In the case of super-gain antennas with 10 or more bays, the likelihood of an exact null is even more remote. There is, however, one condition likely to cause deep nulls. As the height of the transmitting antenna is raised, the null position moves away from the antenna. Figure 8 shows the calculated field intensity pattern of KECA-TV, with antenna height of 5,000 feet above the surrounding terrain. This may be compared directly with Figure 3 which shows the field in-

(Continued on page 28)



Measurements Corporation  
MODEL 82

## STANDARD SIGNAL GENERATOR

20 Cycles to 50 Mc.

**FREQUENCY RANGE:** 20 cycles to 200 Kc. in four ranges. 80 Kc. to 50 Mc. in seven ranges.

**OUTPUT VOLTAGE:** 0 to 50 volts across 7500 ohms from 20 cycles to 200 Kc. 0.1 microvolt to 1 volt across 50 ohms over most of range from 80 Kc. to 50 Mc.

**MODULATION:** Continuously variable 0 to 50% from 20 cycles to 20 Kc.

**POWER SUPPLY:** 117 volts, 50/60 cycles. 75 watts.

**DIMENSIONS:** 15" x 19" x 12".  
Weight, 50 lbs.

**MEASUREMENTS CORPORATION**

BOONTON



NEW JERSEY

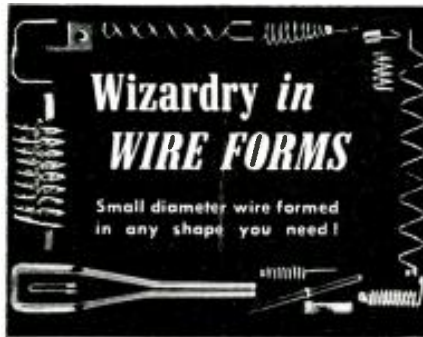

## IMMEDIATE CAPACITY FOR DEFENSE SUB-CONTRACTS

### STRAIGHTENING & CUTTING

Perfect straight lengths to 12 ft.  
.0015 to .125 diameter

### WIRE FORMS

.0015 to .080 diameter

### SMALL METAL STAMPINGS

.0025 to .035 thickness  
.062 to 3 inches wide

★

Specializing in Production of Parts  
for Electronic and Cathode Ray Tubes

Write for Illustrated Folder  
Send Blueprints or Samples for Estimate

**ART WIRE & STAMPING CO.**  
227 High Street Newark 2, N. J.

## Super-Gain Antennas

(Continued from page 27)

tensity for an identical type antenna, except for 500-foot height. It will be seen that the first null has moved out from the 3,500-foot range to 28,000 feet, and that the average level of intensity for the 5,000-foot antenna is down some 20 db from the 500-foot antenna height. This null was found to exist in practice and field intensities were so low as to give unsatisfactory reception over a distance of approximately one mile. The problem was solved by rephasing the antenna so that a null could not exist. This caused a decrease in the main lobe intensity of 0.5 db, but which was not noticeable. The dotted curve of Figure 8 shows the calculated signal strengths with rephasing.

### Ultimate Design

While curve 1 of antenna beam width versus the number of bays is the present design bogie, this type of approach represents the brute force method whereby a symmetrical vertical pattern is used. The optimum vertical pattern would be one that would lay down just sufficient and adequate signal over the area to be covered. This means no *blasting* signal close in and weak signal further out.

Although the ultimate antenna design seems impractical at present, the design characteristics would be: beam width, 1°; power gain, 70; and vertical pattern, approximately cosecant squared.

At 600 mc. the antenna would be approximately 140 feet long; a design based on a minimum performance of constant field strength out to radio optical horizon, when the beam is tilted up 0.48°. This last figure represents the present design sway for 50-mph wind and typical construction.

Summarizing, super-gain antennas are practical and desirable to produce better coverage and higher field strengths. Final engineering design depends upon antenna and tower structural limitations as to bending and flexing in the wind, with the actual beam width required being equal to twice the maximum displacement angle. In addition, downward beam tilt is necessary to minimize field strength changes due to tower sway. Careful control of antenna aperture excitation will provide constant optimum coverage without holes in reception. With present-day standards of design, antenna power gains in the order of 20 appear to be practical.

[In a subsequent article, a practical TV super-gain antenna will be discussed, and data will be offered on generalized design factors, design problems, testing, and assembly.]

## TELEVISION ENGINEERING . . .

The ONLY journal that pin-points its ENTIRE editorial content on vital data of dollar-and-cents value to management and engineering personnel who design, manufacture, operate and maintain every type of television equipment and essential accessories, for commercial and governmental applications.

## OPPORTUNITIES AT THE BRUSH DEVELOPMENT COMPANY

for PHYSICISTS & ELECTRICAL ENGINEERS

Leaders in the Fields of:

- Piezo-electric Crystals and Ceramics
- Electro-acoustics—
- Magnetic Recording—
- Ultrasonics—
- Industrial and Research Instrument—

Increased activities and a highly promising future leads us to add to our highly skilled staff. Conditions are friendly and problems highly stimulating and the field offers opportunity for expansion.

Compensation, pension plans and general personnel policies will make these situations highly attractive to the most able people in the field.

Write Vice President in charge of Engineering  
3405 Perkins Avenue • Cleveland 14, Ohio

## Component Design

(Continued from page 14)

type of glass<sup>3</sup> has been experimentally produced in ribbon form with thicknesses of from .0006" to .020". Laboratory-made capacitors fabricated from this material are reported to have been found highly stable, substantially unaffected by moisture, capable of withstanding high operating temperatures and smaller in physical size.

### Tubular Glass Capacitors

This company is also making tubular glass metallized inductors and capacitors for tuning and trimming applications. The inductors are available in various forms with either single or double pitch metallized inductor conductors, the latter type being suitable for transformer applications. The tuning element of the inductor can be any suitable magnetic material such as powdered irons or ferrites, and the slugs of the tuning capacitor units are made of invar to minimize capacity variations with changes in temperature. Other miscellaneous types of metallized bushings are also available.

### Vitreous Dielectrics

In still another plant,<sup>4</sup> there have been developed techniques for using low-loss vitreous dielectrics in component and circuit manufacture. The dielectrics used are ceramics with a predominance of lead and boron which are said to have characteristics equivalent to the best mica. The techniques are claimed to be, in general, applicable to large scale mechanized production.

Silver is used for the circuit conductors in most applications. Continuous layers of any desired shape can be laminated between layers of dielectric through the use of printed silver, fired to produce a continuous film. The conductivity is essentially that of solid silver. For example, a silver film conductor 0.1" wide has the same conductivity as No. 34 copper wire, but when printed and embedded by this new process, ten amperes can be transmitted for indefinite periods with no ill effects.

Fixed capacitors can be made by laminating several layers of conductor and dielectric, and the process is adaptable to machine production with little labor. The dielectric constant of the ceramic has been found to be in the vicinity of ten; hence only about .03 mfd per cubic inch is obtainable at a rating of 500 volts.

<sup>3</sup>Corning 8871.

<sup>4</sup>Vitramon, Inc., Stepney, Conn.

# IF you use SILVER

## laminated to non-precious base metals in your products

... you will welcome the fast and efficient service of this 53-year old organization and find it a dependable source for the finest of materials ... in sheet, wire or tubing.

Owner-management cuts red tape ... speeds production ... assures you of interested attention and complete satisfaction.

*Your inquiries will be appreciated and replied to ... promptly.*



**The Home of IMPROVED Service**

**The IMPROVED SEAMLESS WIRE COMPANY**  
INCORPORATED 1898  
775 Eddy Street, Providence 5, Rhode Island

## 2 PURPOSE TELEDAPTER

- TELEVISION WAVE FORM OBSERVATION
- RADAR PULSE

LOW \$  
PRICED  
AT **195** F.O.B.  
PLANT

- Converts a DuMont 208 or 304 Scope for use with TV and Radar pulse type signals. Response 3 db down at 5 M.C.
- Completely self-contained including power supply. No modifications to the 208 or 304 Scope required.
- Size matches both Type 208 and 304 scopes and tie plates are furnished to fasten both instruments together.

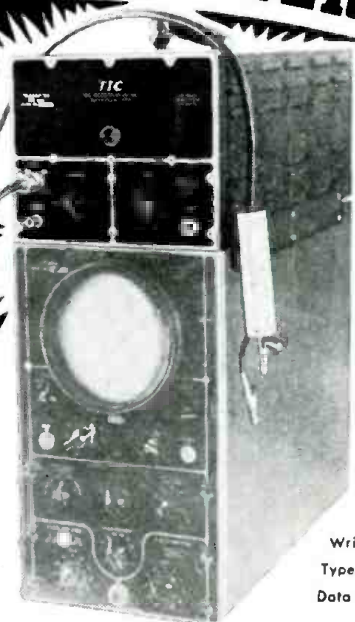

Write for  
Type 1000  
Data Shee.

Convert your Type 208 and 304 Scopes for TV and Radar testing, for only \$195.00

# TIC

Manufacturers of a complete line of TV and Radar Test Equipment

## Tel-Instrument Co. Inc.

50 PATERSON AVENUE • EAST RUTHERFORD, N. J.

# 30-Inch TV Receiver

(Continued from page 11)

currents required to provide the necessary deflection power, the transformer became saturated. Accordingly, the vertical deflection amplifier output transformer was modified through the introduction of a 5-mil copper shim type of air gap. This gap occurs at two places in the coil providing a total gap of 10 mils. Copper was used because some non-magnetic material was required; yet it was found that most insulating materials would compress and not hold the gap accurately. Accuracy of the gap was important because, if too small, we would encounter the saturation condition in the core which produces packing on the bottom of the picture. On the other hand, if the air gap were made too large, the picture would stretch at the top, in all probability due to an impedance mismatch between the output transformer and the vertical winding on the deflection yoke. In the high voltage section of the power supply chassis eight tubes were included: a 6SB7 twin triode connected as a blocking oscillator and synchronized by the synchronizing signals from the main chassis. The output of this blocking oscillator is fed into a pair of 6BG6s, connected in parallel. The blocking oscillator, although synchronized by the synchronizing signals from the main chassis operates at twice line frequency or 31,500 cps. The 6BG6 tubes have their output connected to the high voltage coil, which is a pi-wound type, using a slug of ferrite, which has a stepup ratio with a voltage output of approximately 25,000 volts peak-to-peak sine wave; this can be adjusted from 20,000 to 25,000 volts *dc* output, by a control which is provided. This tube complement then serves as the high voltage source at 25,000 volts *dc* for the accelerating potential of the tube; the high voltage output is applied through a bleeder resistor to the grid of a 6SJ7 control tube, which in turn controls the grid voltage of a 6W6. This latter tube acts as a variable resistor in the 6BG6 screen circuit, increasing the screen voltage when the output voltage drops and decreasing it when the output voltage tends to rise.

A VR75 serves to provide a constant voltage on the cathode of the 6SJ7 to provide a fixed voltage reference level. This 6SJ7, 6W6, and VR75 thus form the high-voltage regulator circuit.

The high-voltage section of the power supply chassis has three controls, one of which controls the frequency of the oscillator and is set for correct waveform and dip in the driver screen current. The second control is a drive control, which controls the amount of signal applied to the driver control grids and is set for maximum dip in driver screen current. The third control is the high-voltage regulator control which controls the bias on the 6SJ7 regulator, thus controlling the average flow of current through it, which in turn determines the high voltage available at the rectifier output. This was found to provide an adjustment which permits the selection of accelerating potential. Included also in the high-voltage power-supply chassis, and associated with the low-voltage power-supply section, is a delay relay circuit which utilizes the warmup period of a 6AL5 twin diode to delay the application of a plate potential to the high voltage and deflection amplifier, until after the cathodes have had the opportunity of reaching operating temperature. This feature prolongs tube life and prevents the application of high surge potentials to the components associated with these tubes.

Another feature is a sweep failure protection circuit with a 6AL5 which utilizes two tubes and two relays. This sweep failure protection circuit will disable the high voltage supply in case either the horizontal or vertical deflection circuits fail, and it provides good protection for the 30-inch tube. The 6AL5 rectifies part of the output of the horizontal and part of the output of the vertical deflection amplifier. The two *dc* voltage, thus obtained, are applied to two sections of a 6SN7 in such a manner that when there is deflection potential present the two sections of the 6SN7 respectively conduct and hold the plate relay closed. Both relay contacts are wired in series with the cathode of the high-voltage driver tubes, so that failure of either sweep circuit would immediately cut off the high voltage supply or accelerating potential for the picture tube.

Two regulated transformers<sup>3</sup> are used in the chassis. One of them appears in the receiver chassis<sup>2</sup> and the other one in the power supply chassis to provide the low voltage source for

the deflection circuits. It is necessary that this low-voltage source be a constant voltage so as to avoid sharp changes of picture size with line voltage fluctuations. Were the second regulated transformer not provided, the effect on picture size of line voltage fluctuations would be quite pronounced. This has been found due to the fact that the high voltage is regulated by a vacuum-tube type of regulator circuit and can remain constant, but deflection power is markedly reduced as the line voltage dips, or increased as the line voltage rises. In ordinary receivers which do not utilize a regulated high-voltage supply there is the fortunate tendency for the high voltage to decrease as the line voltage decreases, simultaneously with the decrease in deflection power, so that the effect upon picture size is partially counteracted by these two effects. The opposite is, of course, equally true, as the line voltage rises both the high voltage and deflection power tends to rise.

## Credits

The writer wishes to acknowledge the assistance of M. Gruenspecht, who collected the material which served as a basis for this article.

<sup>3</sup>Sola, 2RA-109.

## ADVERTISERS IN THIS ISSUE

TELEVISION ENGINEERING

MAY, 1951

AMPERITE COMPANY .....	31
Agency: H. J. Gold Co.	
ART WIRE & STAMPING CO.....	28
Agency: United Adv. Agency	
BIRTCHEE CORP. ....	26
Agency: Crossley & Jeffries, Inc.	
BOONTON RADIO CORP.....	31
Agency: Frederick Smith	
BRUSH DEVELOPMENT CO.....	28
CORNELL-DUBILIER ELECTRIC CORP.....	27
Agency: Reiss Advertising, Inc.	
ALLEN B. DU MONT LABORATORIES, INC.	
Agency: Austin C. Lescarboura & Staff	Inside Front Cover
GERING PRODUCTS, INC.....	31
Agency: Ira S. Kalin Co.	
GUARDIAN ELECTRIC CO.....	26
Agency: Kennedy & Co.	
IMPROVED SEAMLESS WIRE CO.....	29
Agency: Knight & Gilbert, Inc.	
MEASUREMENTS CORPORATION.....	28
Agency: Frederick Smith	
RADIO CORPORATION OF AMERICA	
Agency: J. Walter Thompson Co.	15, 25, Back Cover
SHELDON ELECTRIC CO.....	19
Agency: Corbin Adv. Agency	
STACKPOLE CARBON CO.....	23
Agency: The Harry P. Bridge Co.	
SPRAGUE ELECTRIC CO.....	Inside Back Cover
Agency: The Harry P. Bridge Co.	
TEL INSTRUMENT CO.....	29
Agency: Lewis Adv. Agency	
THOMAS ELECTRONICS, INC.....	2
Agency: Burton Browne, Advertising	
U. S. TREASURY DEPARTMENT.....	20
WELLS SALES, INC.....	32
Agency: Turner Adv. Agency	
ZINC TRADING CO.....	30

**600 VOLT ELECTRIC UTILITY**  
 WIRE, 3300 FEET TO REEL, 2 CONDUCTOR #14 GAUGE, BLACK MICA, BRAIDED COVER, HEAVY RUBBER INSULATED, 7 STRAND TINNED COPPER, IRREPLACEABLE TODAY'S MARKET. U. S. GOV'T COST \$250.00. OUR LOW PRICE, F.O.B. N. Y., ONLY \$68.00 PER 3300-FT. REEL.

**ZINC TRADING COMPANY**  
 244 RIVERSIDE DR., NEW YORK 25, N. Y.  
 MO 6-3438



## Briefly Speaking . . .

COOPERATIVE RESEARCH, linking the labs of industry and universities, often cited as an ideal program, has become the basis of a unique 5-year program involving Philco and MIT. Under the plan, there will be an exchange of information on research covering military and commercial electronics, television, etc. The program also calls for a series of special conferences and seminars, an exchange of visits, the use of scientific libraries and a joint policy to cover inventions and patents. . . . The vitreous-enamelled, round-power rheostat (150-500 watt) facilities of Rex Rheostat Co., 3 Foxhurst Rd., Baldwin, L. I., have been purchased by P. R. Mallory Co., Indianapolis, Indiana. Rex will continue to manufacture its line of tubular slide-wire rheostats, potentiometers and resistors. . . . A 650-foot, one-story building at 3410-3450 W. Hopkins St., Milwaukee, Wis., costing in excess of one-million dollars, has been purchased by Globe-Union, Inc., for Centralab, to be used in the production of classified defense equipment. . . . A course in communications has been announced for the summer session of '51 at M.I.T. The course to be given between June 18th and July 6th, under the direction of Dr. Y. W. Lee, associate professor of electrical engineering, will include lectures by Dr. Lee, Dr. W. B. Davenport, Jr., Dr. J. B. Wiesner, Dr. R. M. Fano, Dr. J. C. R. Licklider, and Dr. Alex Bavelas. The course will be given under the auspices of the M.I.T. department of electrical engineering, in conjunction with the research laboratory of the electronics and the acoustics laboratory. Topics to be covered will include factors involved in modern communications theory. . . . Permanent magnets, containing no critical material, have been developed by the metallurgical laboratories ofsylvania Electric. . . . Cannon Electric Co. has opened a new eastern plant at 191 Kimberly St., East Haven, Conn. E. C. Quackenbush will head the engineering department of this newly created eastern division. . . . A. T. & T. are installing a Philco microwave television link between Cincinnati and Dayton. The system is scheduled to operate in the 6000 to 7000-mc range and will feature use of the double heterodyne remodulation principle. . . . Expanded production facilities, involving 65,000 square feet of factory space, are now being used by the Technical Appliance Corp. at Sherburne, N. Y. . . . William E. Harrison, president of Harrison Radio Corp., in New York City, has been appointed to formulate a proposal for submission to the Office of Civilian Requirements, to provide priorities to hams in the procurement of essential equipment. . . . A 107-page pocket-size handbook listing the essential characteristics of receiving tubes has been published by the G.E. tube division. Basing diagrams for 806 tube types are shown on the pages with the tube data. Included are a listing of the receiving and picture tubes recently announced for television applications. . . . The N. Y. and international sales offices of the Raytheon Manufacturing Co., Waltham, Mass., are now located at 19 Rector St., New York 6. . . . A 4-page bulletin describing facilities and equipment available for production, research and testing, has been released by Buck Engineering Co., Inc., 37-41 Marcy St., Freehold, N. J.

TeleVision Engineering, May, 1951



The **Q-METER**  
TYPE 160-A

### ACCURATE • DEPENDABLE • VERSATILE

For the measurement of Q, inductance, and capacitance, the 160-A Q-Meter is the universal choice of radio and electronics engineers. Its wide frequency coverage from 50 kc. to 75 mc. is an outstanding feature which makes possible the accurate and rapid evaluation of components and insulating materials at the actual operating frequency.

#### SPECIFICATIONS

OSCILLATOR FREQUENCY RANGE:  
50 kc. to 75 mc. 8 self contained ranges.

OSCILLATOR FREQUENCY ACCURACY:  
±1%, 50kc.-50mc. ±3%, 50mc.-75 mc.

Q-MEASUREMENT RANGE: Directly calibrated in Q, 20-250. "Multiply Q-By" Meter calibrated at intervals from x1 to x2, and also at x2.5, extending Q-range to 625.

Q-MEASUREMENT ACCURACY: Approximately 5% for direct reading measurement, for frequencies up to 30 mc. Accuracy less at higher frequencies.

CAPACITANCE CALIBRATION RANGE:  
Main capacitor section 30-450 mmf, accuracy 1% or 1 mmf, whichever is greater.

Vernier capacitor section ±3 mmf., zero, -3 mmf. calibrated in 0.1 mmf. steps. Accuracy = 0.1 mmf.

Write for literature containing further details

**BOONTON RADIO**

BOONTON, N.J. U.S.A.

Corporation



## for SPECIAL insulation problems of Polyethylene AND Vinyl

. . . we offer our facilities for special compounds, special design, extrusion and fabrication. Consult:

Extruded Products Div.

## GERING PRODUCTS INC.

Pioneers in Electronic Insulation  
DEPT. TV  
KENILWORTH, N. J.

## AMPERITE Studio Microphones at P.A. Prices

Ideal for  
BROADCASTING  
RECORDING  
PUBLIC ADDRESS

"The ultimate in microphone quality," says Evan Rushing, sound engineer of the Hotel New Yorker.

• Shout right into the new Amperite Microphone—or stand 2 feet away—reproduction is always perfect.

• Not affected by any climatic conditions.  
• Guaranteed to withstand severe "knocking around."



Models

RBLG—200 ohms

RBHG—Hi-imp.

List \$42.00



"Kontak" Mikes  
Model SKH, list \$12.00  
Model KKH, list \$18.00

**Special Offer:** Write for Special Introductory Offer, and 4-page illustrated folder.

**AMPERITE Company, Inc.**

561 BROADWAY • NEW YORK 12, N. Y.

Canada: Atlas Radio Corp., Ltd., 360 King St. W., Toronto





**NEW!**

**ACE HIGH**

• • **for miniaturization,  
mounting, and temperature problems**

Here they come, right off the top of the deck, to fill in what's been needed—new ways of mounting subminiature capacitors in military electronic equipment!

You'll find side stud, end stud, threaded neck, and two types of side bracket capacitors in Sprague's new 16 page Engineering Bulletin 213-B

These new Sprague-pioneered designs make even broader the world's most complete line of solder-seal terminal metal-

encased subminiature paper capacitors.

And they're now available as standard in a 125°C. temperature rating Vitamin Q<sup>®</sup> capacitor series. Voltage ratings range from 100 to 1000 volts in both inserted tab and extended foil constructions.

And remember, Sprague Capacitors are the standard of dependability for critical electronic circuits. Write for your copy of Bulletin 213-B which gives the complete Sprague Subminiature Story.

**SPRAGUE**

PIONEERS IN

**SPRAGUE ELECTRIC COMPANY**

NORTH ADAMS, MASSACHUSETTS

ELECTRIC AND ELECTRONIC DEVELOPMENT

*Another* **RCA FIRST!**

*Electrostatic  
Focusing*



RCA-17GP4

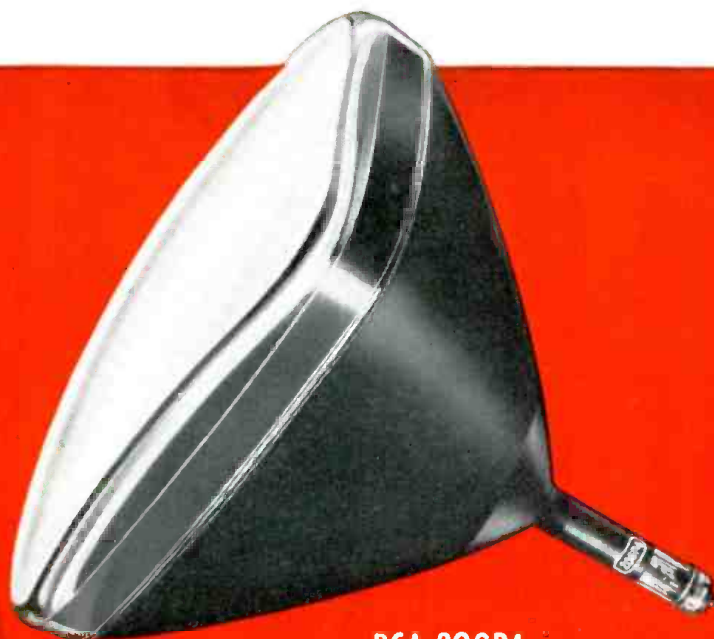

RCA-20GP4



RCA-14GP4

The Fountainhead of Modern Tube Development is RCA

## ...to conserve critical materials

RCA engineering has once again taken the lead by developing an improved method of electrostatic focusing that offers the television industry important savings in critical materials. Incorporating this new RCA development are three new rectangular picture tubes that require no focusing coil or focusing magnet. The tubes provide high-quality pictures on a par with those obtained from kinescopes employing electromagnetic focus.

Featuring electrostatic focusing, the RCA types 14GP4, 17GP4, and 20GP4 use an

electron gun of improved design that provides good uniformity of focus over the entire picture area. Furthermore, focus is maintained automatically with variation in line voltage and with adjustment of picture brightness. Need for alignment of a focusing magnet is eliminated and, therefore, tube installation and adjustment for optimum performance are simplified.

Because the electron gun is designed so that the focusing electrode takes negligible current, the voltage for the focusing electrode can be provided easily and economically. In other respects, the RCA 14GP4, 17GP4, and 20GP4 are similar to magnet-

ically focused types—the 14EP4, 17CP4, and 20CP4.

RCA Application Engineers are ready to co-operate with you in adapting the 14GP4, 17GP4, 20GP4 and associated components to your present designs. For further information, write RCA, Commercial Engineering, Section 58ER, Harrison, N. J.

*Another* RCA-developed component

A new Horizontal-Deflection-Output and High-Voltage Transformer designed particularly for use with the new electrostatic-focus picture tubes will be available shortly.



**RADIO CORPORATION of AMERICA**  
ELECTRON TUBES  
HARRISON, N. J.